



UNITED BRASS WORKS, INC.
 714 S. Main St., Randleman, NC 27317
 Tel: 800-334-3035 Fax: 800-498-4696 www.ubw.com



Model 14 Gate Valve (Overseas)

125PSI Cold Water Working Pressure
(Not Recommended for Steam)
Solid Wedge
Non-Rising Stem
Screwed Bonnet

MATERIAL LIST

NO.	DESCRIPTION	MATERIAL
1	Hex Nut	Steel
2	Hand Wheel	Cast Iron
3	Packing Nut	Brass
4	Packing	Graphite
5	Bonnet	Bronze
6	Body	Bronze
7	Gate	Bronze
8	Stem	Brass

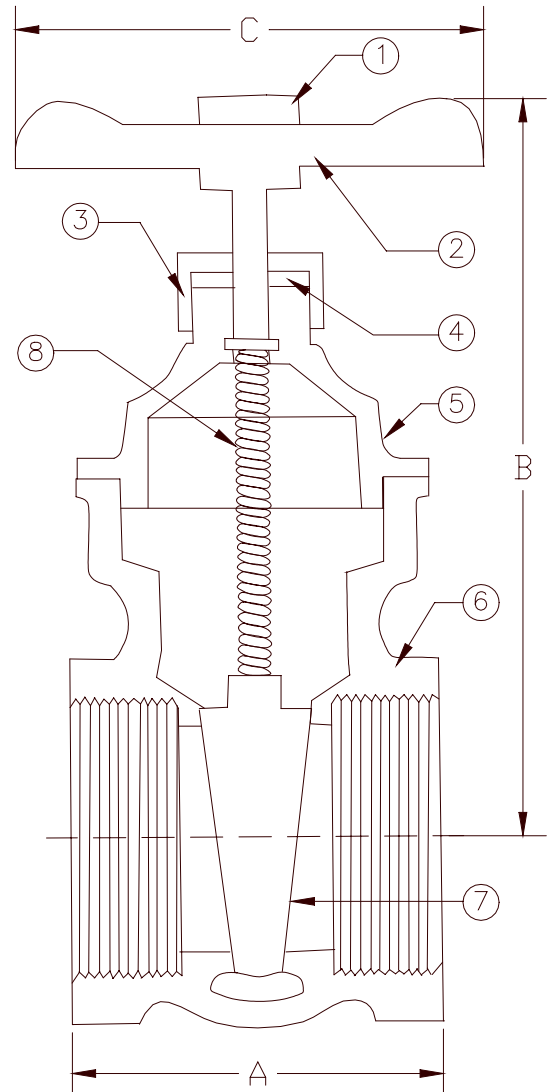

Size	3/8"	1/2"	3/4"	1"	1 1/4"	1 1/2"	2"
A	1.63	1.69	1.88	2.19	2.38	2.88	2.81
B	3.06	3.00	3.50	4.06	4.75	5.19	6.19
C	2.13	2.13	2.13	2.38	2.8	2.88	3.25
Ship Wgt. (lbs.)	0.63	0.63	0.81	1.10	1.80	2.10	3.20
Qty. Per Ctn.	12	12	6	6	2	2	2



UNITED BRASS WORKS, INC.
 714 S. Main St., Randleman, NC 27317
 Tel: 800-334-3035 Fax: 800-498-4696 www.ubw.com



Model 15 Gate Valve (Conforms to MSS-SP-80-97)

125 WSP @ 350 ° Max
200 WOG * 100% Pressure Tested
Threaded Ends * Non-Rising Stem

MATERIAL LIST

NO.	DESCRIPTION	MATERIAL
1	Nut	Steel
2	Marker Disc	Aluminum
3	Hand Wheel	Aluminum
4	Packing Nut	Brass
5	Packing Gland	Brass
6	Packing	NAFG
7	Upper Bonnet	Bronze
8	Lower Bonnet	Bronze
9	Stem	Brass
10	Wedge	Brass
11	Body	Bronze

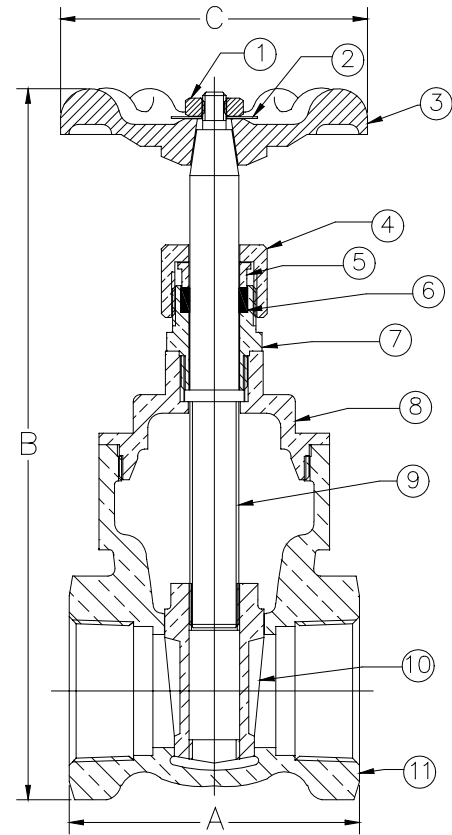

Size	3/8"	1/2"	3/4"	1"	1 1/4"	1 1/2"	2"	2 1/2"
A	1.88	2.00	2.13	2.38	2.63	2.88	3.25	4.13
B	2.13	2.13	2.38	2.75	3.00	3.25	3.75	4.50
C	3.75	4.13	5.00	5.50	5.50	6.00	7.13	8.50
Ship Wgt. (lbs.)	0.70	0.80	0.90	1.50	2.10	2.80	4.30	9.20
Qty. Per Ctn.	12	12	6	6	4	2	2	2



UNITED BRASS WORKS, INC.
 714 S. Main St., Randleman, NC 27317
 Tel: 800-334-3035 Fax: 800-498-4696 www.ubw.com



Model 16 Gate Valve

125WSP @ 350° Max
200 WOG
100% Pressure Tested
Non-Rising Stem
Copper to Copper Ends

MATERIAL LIST

NO.	DESCRIPTION	MATERIAL
1	Nut	Steel
2	Marker Disc	Aluminum
3	Handwheel	Aluminum
4	Packing Nut	Brass
5	Packing Gland	Brass
6	Packing	NAFG
7	Upper Bonnet	Bronze
8	Lower Bonnet	Bronze
9	Stem	Brass
10	Wedge	Brass
11	Body	Bronze

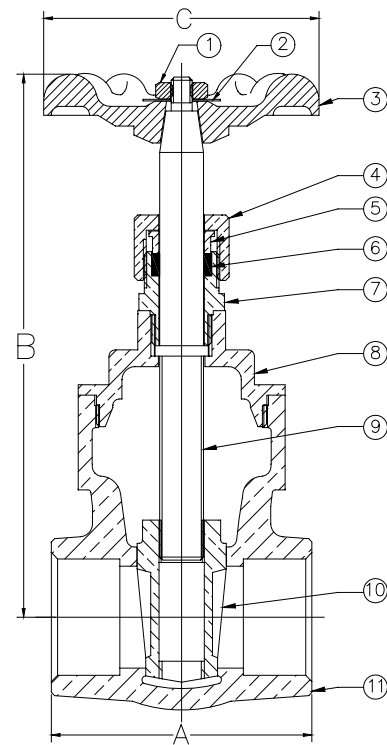

Size	3/8"	1/2"	3/4"	1"	1 1/4"	1 1/2"	2"
A	1.92	2.13	2.63	2.67	3.41	3.69	4.00
B	2.09	2.09	2.42	2.75	3.00	3.20	3.64
C	3.34	3.81	4.31	4.98	5.13	5.63	7.64
Ship Wgt. (lbs.)	0.70	0.80	0.90	1.50	2.10	2.80	4.30
Qty. Per Ctn.	12	12	6	6	4	2	2



UNITED BRASS WORKS, INC.
 714 S. Main St., Randleman, NC 27317
 Tel: 800-334-3035 Fax: 800-498-4696 www.ubw.com



Model 17 Gate Valve
Conforms to MSS-SP80-97

150WSP @ 350°F Max
300 WOG
Solid Wedge * Screwed Bonnet * Rising Stem

MATERIAL LIST

NO.	DESCRIPTION	MATERIAL
1	Nut	Steel
2	Hand Wheel	Cast Iron
3	Packing Nut	Brass
4	Packing	PTFE
5	Bonnet	Bronze
6	Body	Bronze
7	Gate	Bronze
8	Stem	Brass
9	Packing Gland	Brass

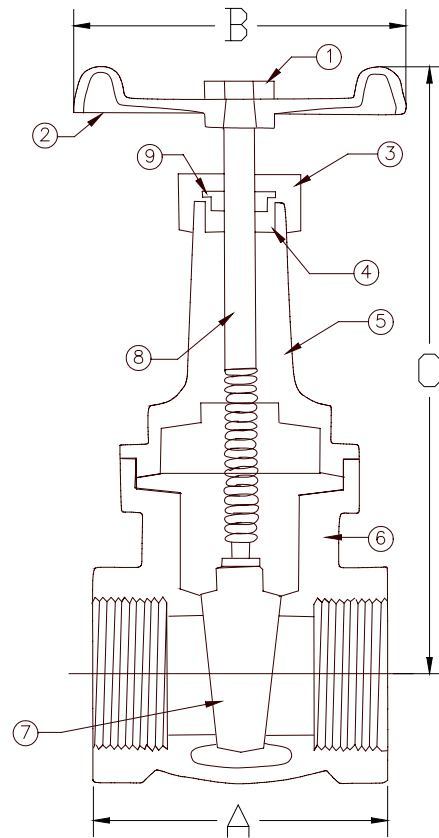

Size	½"	¾"	1"	1 ¼"	1 ½"	2"
A	2.31	2.44	2.88	3.13	3.38	3.88
B	2.50	2.56	2.63	3.00	3.56	4.13
C (Open)	5.38	6.31	7.56	8.75	10.25	12.50
C (Closed)	4.25	5.00	5.63	6.25	7.00	8.63
Ship Wgt. (lbs.)	1.10	1.50	2.70	3.40	4.80	7.20
Qty. Per Ctn.	12	6	6	4	2	2