



UNITED BRASS WORKS, INC.
 714 S. Main St., Randleman, NC 27317
 Tel: 800-334-3035 Fax: 800-498-4696 www.ubw.com



Model 226UT Y-Blow Down Valve

Complies with MSS-SP-80-97
200 WSP @ 406° Max • 400 WOG
Non-Shock Service • 100% Pressure Tested
Threaded Ends • Rising Stem • Swivel Disc Holder
PTFE Disc • Integral Seat

Care must be taken in blow down piping so that no water hammer effect causes shock to the "Y" blow down valve, especially in cases where a boiler has two blow down lines. In such cases both lines should be piped to a common set of blow down valves or each blow off line should be piped separately to the blow down separator. Excessive water hammer or shock can destroy valves and piping and could cause injury.

MATERIAL LIST

NO.	DESCRIPTION	MATERIAL
1	Jam Nut	Steel
2	Hand Wheel	Aluminum
3	Stem	Naval Brass
4	Packing Nut	Brass
5	Packing Gland	Brass
6	Packing	NAFG
7	Bonnet	Bronze
8	Bonnet Nut	Bronze
9	Lock Nut	Brass
10	Disc Holder	Brass
11	Body	Bronze
12	Marker Disc	Aluminum

Size	1"	1 1/4"	1 1/2"	2"
A	4.75	5.56	6.25	7.75
B	5.75	7.00	7.75	8.75
Ship Wt. (lbs.)	4.20	6.10	9.00	15.00
Qty. Unit Pack	4	4	2	2

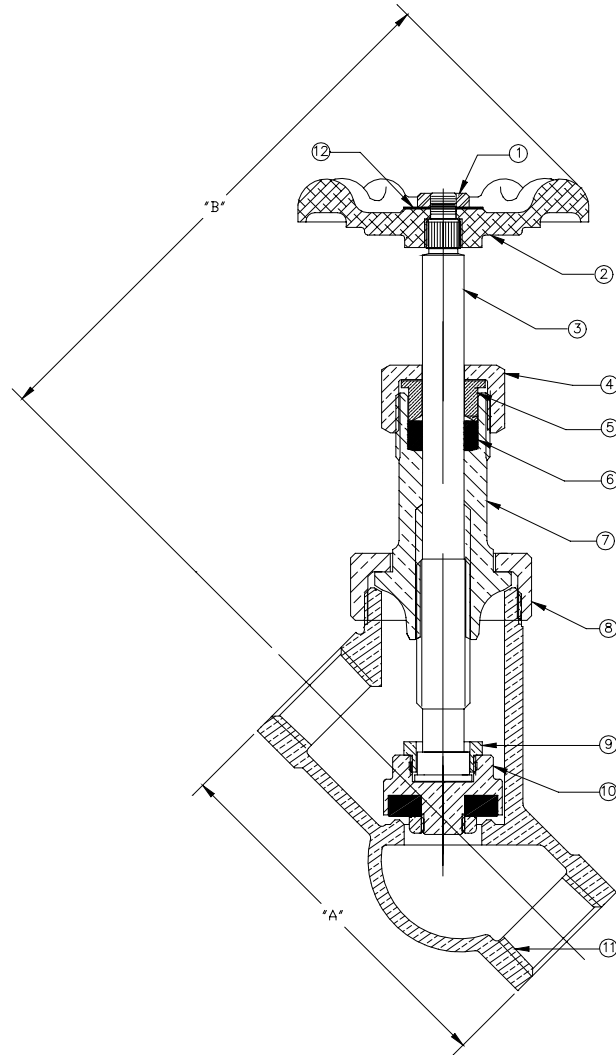



UNITED BRASS WORKS, INC.
 714 S. Main St., Randleman, NC 27317
 Tel: 800-334-3035 Fax: 800-498-4696 www.ubw.com



Model 325U Y-Blow Down Valve

Complies with MSS-SP-80-97
 300 WOG • 600 WOG • Non-Shock Service
100% Pressure Tested • Threaded Ends
Rising Stem • Swivel Disc Holder
Seat & Disc 400-500 Brinnell Stainless Steel

Care must be taken in blow down piping so that no water hammer effect causes shock to the "Y" blow down valve, especially in cases where a boiler has two blow-down lines. In such cases both lines should be piped to a common set of blow down valves or each blow off line should be piped separately to the blow down separator. Excessive water hammer or shock can destroy valves and piping and could cause injury.

MATERIAL LIST

NO.	DESCRIPTION	MATERIAL
1	Jam Nut	Steel
2	Hand Wheel	Aluminum
3	Stem	Naval Brass
4	Packing Nut	Brass
5	Packing Gland	Brass
6	Packing	NAFG
7	Bonnet	Bronze
8	Bonnet Nut	Bronze
9	Lock Nut	Brass
10	Disc	Stainless Steel
11	Body	Bronze
12	Seat	Stainless Steel

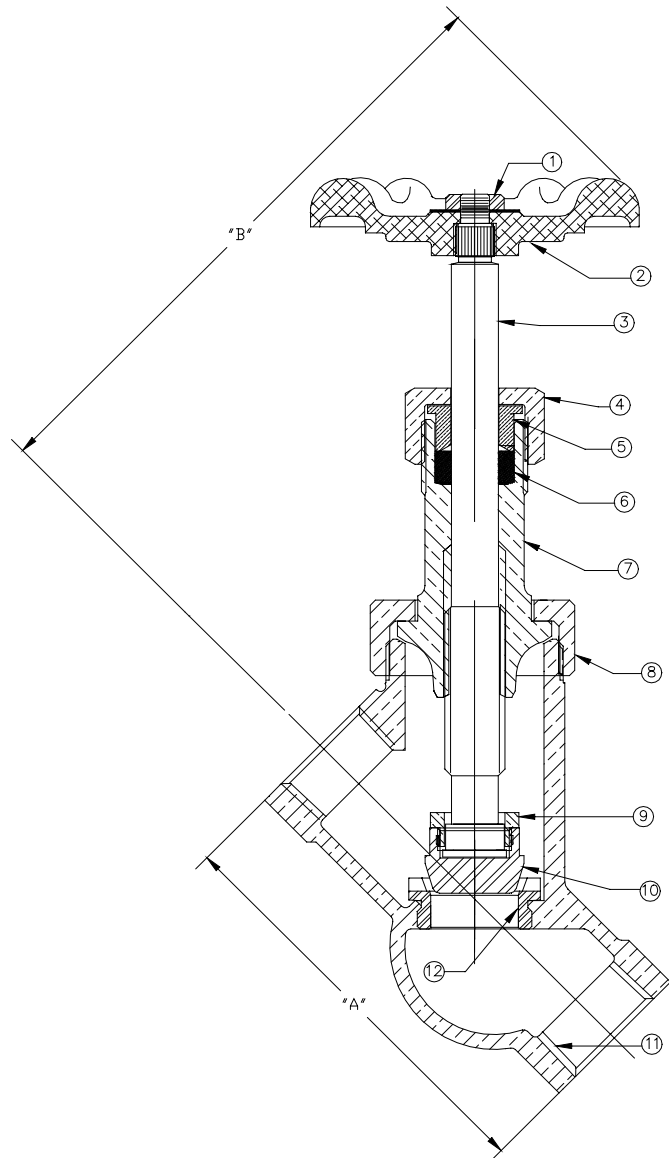

Size	1"	1 ¼"	1 ½"	2"
A	4.75	5.56	6.25	7.75
B	5.75	7.00	7.75	8.75
Ship Wt. (lbs.)	4.75	6.25	8.60	15.11
Qty. Unit Pack	4	4	2	2