

POWERS

A WATTS INDUSTRIES CO.

TECHNICAL INSTRUCTIONS

VisuGuard LCD™

Form TIVISU LCD v2

DESCRIPTION

Concealed, tub and shower or shower only pressure balancing mixer with battery operated, LCD temperature display for use in shower applications. Features a single AAA alkaline battery for up to four years of continuous life. Rugged, brass valve body construction with diaphragm-type pressure balancing mechanism. Cartridge components manufactured of Celcon® to resist lime buildup and corrosion. Adjustable handle rotation stop reduces risk of handle over-adjustment. Opens in cold water position to maximize bather safety. Battery and temperature display are housed in an easy-access, watertight enclosure.

Valve trim features:

- Ergonomically-designed, chrome-plated, metal-cast faceplate and handle
- ADA-compliant handle operation

SPECIFICATIONS

Connections 1/2" NPT inlets and 1/2" sweat outlets

Battery Single AAA alkaline

Temperature Display 1/2" [13 mm] LCD readout
(factory set for either °C or °F; accurate to 1/10 of a degree)

Temperature Range (Display) -58–158 °F [-50–70 °C]

Capacity 6.0 gpm @ 45 psi differential
[22 L/min @ 310 kPa]
(±0.5 gpm [±1.9 L/min])

Maximum Inlet Temperature 180°F [82°C]

Maximum Operating Pressure 125 psig [862 kPa]

Handle Rotation Stop Standard and adjustable

Wall Seal Gasket Supplied with valve

Agency Approvals Meets requirements of ASSE 1016
CSA approved, ADA-compliant handle

Shipping Weight 4.7 lbs. [2.1 kg]

APPLICATION

The VisuGuard LCD is particularly recommended in showers and shower bath installations for motels, hotels, dormitories, health care facilities, and single family residences.

OPERATION (SEE FIGURE 1)

Hot and cold water enter their respective ports and the flow of water is equalized through the action of the balance poppet (1). The entire balancing poppet assembly is contained in a Celcon chamber (2). This chamber is replaceable as a complete cartridge. After the hot and cold flows are equalized, they are mixed by the action of a mixing plate (3). As the temperature adjustment stem is rotated to maximum hot water temperature, the mixing plate passes the required proportion of hot and cold water to produce the control point. With the adjustment stem in its full clockwise position, shutoff is obtained by closing both supplies.

The maximum temperature stop (4) allows the user to set the maximum discharge temperature. This mixer does not recognize supply water temperature changes, so any variation in the water temperature will affect the control point **and** the maximum temperature setting.



F473 shown
C473 Celsius

FIGURE 1 - OPERATION

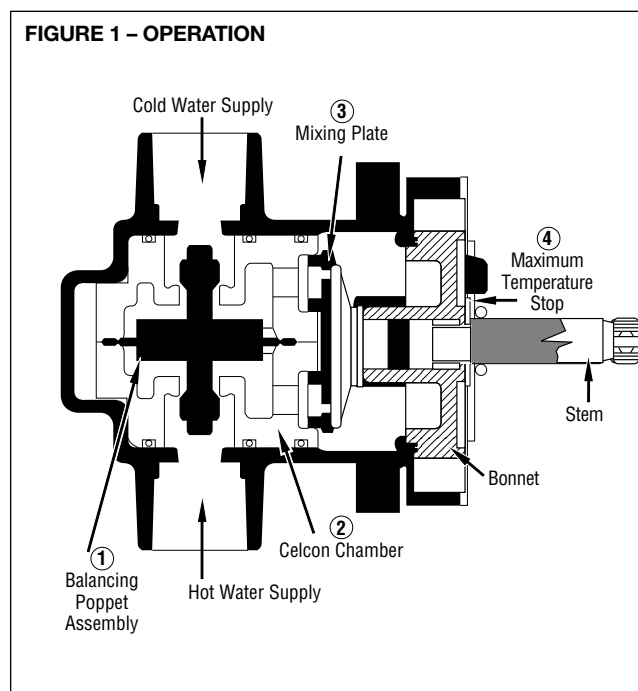

NOTE: Following any maintenance of unit, maximum temperature stop must be reset. See page 4 for instructions.

MAINTENANCE

Troubleshooting

What to look for:

- 1. The flow of water is less than desired.**
 - a. Valves upstream from supply not fully open.
 - b. Low supply pressures.
 - c. Accumulation of lime deposits in hot water pipes, restricting the flow of hot water.
 - d. Showerhead clogged.
 - e. Checkstops may not be fully open.
 - f. Low hot water supply temperature.
- 2. Flow of water is completely shut off.**
 - a. Valves upstream from supply completely closed.
 - b. Failure of hot or cold water supply pressure. The Hydroguard is constructed to restrict the flow of water on hot or cold water supply failure.
 - c. Checkstops closed.
- 3. Flow is untempered hot or cold water.**
 - a. The water supplies are connected to the wrong ports. Reconnect valve supplies to proper ports.
 - b. Diaphragm is ruptured; replace with new cartridge.
 - c. Check for foreign material that may be clogging the cartridge strainers.
- 4. Flow of water continues when VisuGuard LCD is shut off.**
 - a. Worn shut-off discs. Replace worn disc.
 - b. Scratched mixing plate.
 - c. Erosion. Contact a Powers applications engineer to order replacement parts.

5. Maximum temperature is too low.

- a. Accumulation of lime deposits in hot water pipes, which restricts the flow of hot water.
- b. The concealed maximum temperature limit stop is not at its maximum adjustment. See page 5 to set the maximum temperature limit stop.
- c. Hot water temperature is too low.

6. Standard inlets are desired.

See Figure 2 for instructions on standard inlets (with cold water entering the COLD port). With mixer in closed position, the **notch** in the top spline on the stem **must FACE the outlet**.

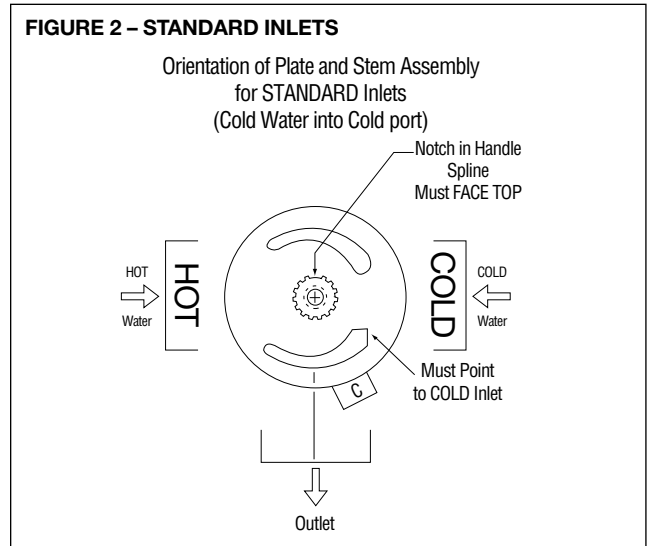

TROUBLESHOOTING

Description	Recommended Repair Kit	Kit Number and Contents
<ol style="list-style-type: none"> 1. Water leaks at stem and/or bonnet. 2. Flow of water continues after mixer is turned off. 	Gasket and Disc Replacement	410-182 Items 3, 3A, 8, 12, 16
<ol style="list-style-type: none"> 1. Variable or untempered discharge temperature. 	Balance Chamber	410-183 Items 8, 12, 13, 14, 15, 16, 17
<ol style="list-style-type: none"> 1. Flow continues after mixer is turned off. 2. Handle splines on stem damaged. 	Throttling Stem and Plate Replacement	410-378 Items 3, 3A, 8, 9, 10, 11, 12 Discard Extra O-rings
<ol style="list-style-type: none"> 1. Cartridge slips while seated in body. 2. Flow of water continues after mixer is turned off, and all other seals have been replaced. 	Oversize 410 Inlet Seal Kit	410-570 Items 3, 3A, 8, 12, 16 Discard oversized O-ring (not shown)
Electronics		
<ol style="list-style-type: none"> 1. Display not working (blank). 	Battery not properly installed or "dead".	Replace or reinstall battery correctly.
<ol style="list-style-type: none"> 2. Temperature does not change on display when handle is turned. 	Temperature probe not installed.	Remove plate and install.(See Figure 7)
<ol style="list-style-type: none"> 3. Temperature display does not respond rapidly when handle is turned. 	Temperature probe not properly installed.	Reinstall (See Figure 7).

Notes:

1. Use silicone provided on all O-rings and related surfaces. Never use grease.
2. Some kits contain parts for all models; discard extra parts as appropriate.

PARTS

Valve Assembly

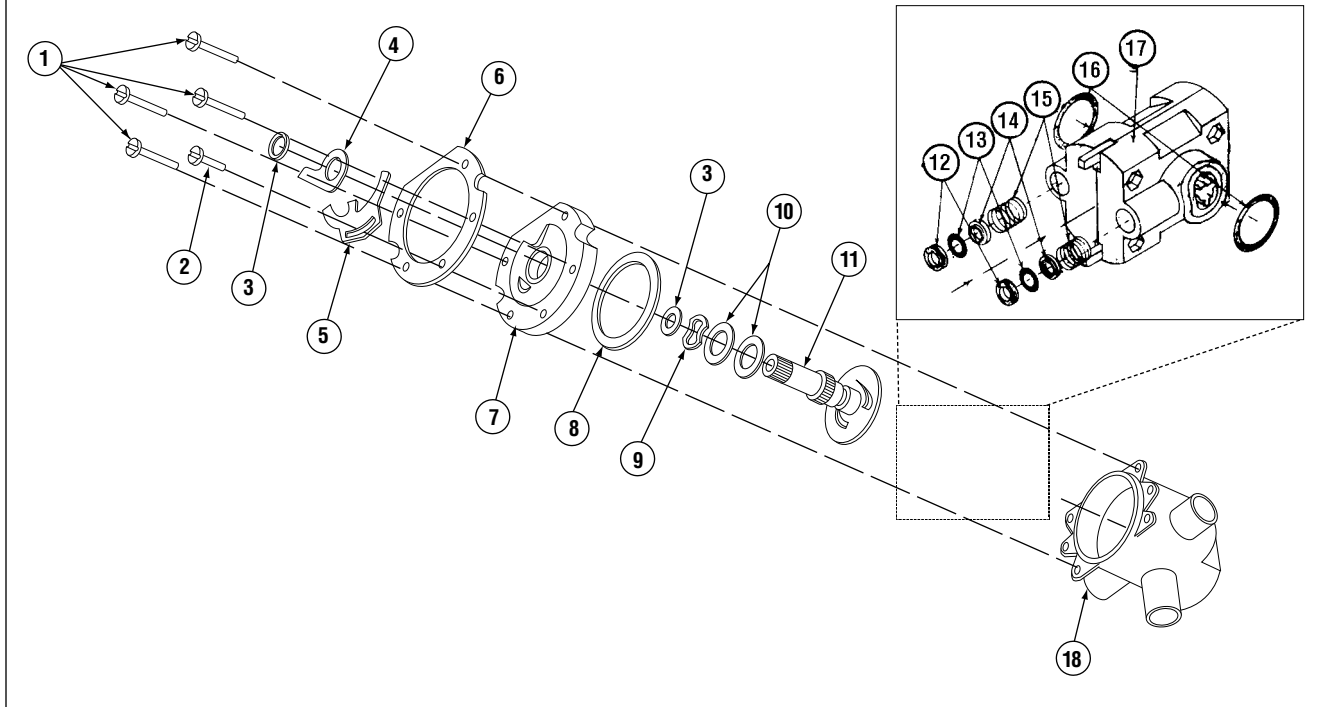

**Series 470 VisuGuard LCD Pressure equalizing mixer.
Poppet-type construction. Adjustable maximum temperature stop.**

Item	Part Description	Kit/Part No.	Quantity	Material
1	Bonnet Screws (10-32 x 5/16")	030-885	4	Stainless Steel
2	Adjustment Stop Screw (10-32 x 5/16")	030-884	1	Stainless Steel
3	O-Rings (3/8" x 1/2" x 1/16")	047-020	4	Buna-N
4	Maximum Temperature Stop	401-218	1	Brass
5	Adjustment Stop	401-278	1	Stainless Steel
6	Support Ring	410-377	1	Stainless Steel
7	Bonnet	401-162	1	Noryl
8	Bonnet Gasket (Rainbow Style)	410-146*	1	Rubber
9	Wavy Washer	410-145*	1	Stainless Steel
10	Flat Washers	410-144	4	Synthane
11	Throttling Stem	410-375	-	Brass Stem Celcon Plate
12	Shut-off Disc	400-023	1	Buna-N
13	O Rings (2)	410-366	25	Buna-N
14	Guide	410-427	1	Brass
15	Spring	410-138	1	Monel
16	O Ring	047-031	1	Buna-N
17	Cartridge	410-440	1	Celcon
18	Valve Body	-	1	Brass

PARTS

See laser etched ring to determine valve model.

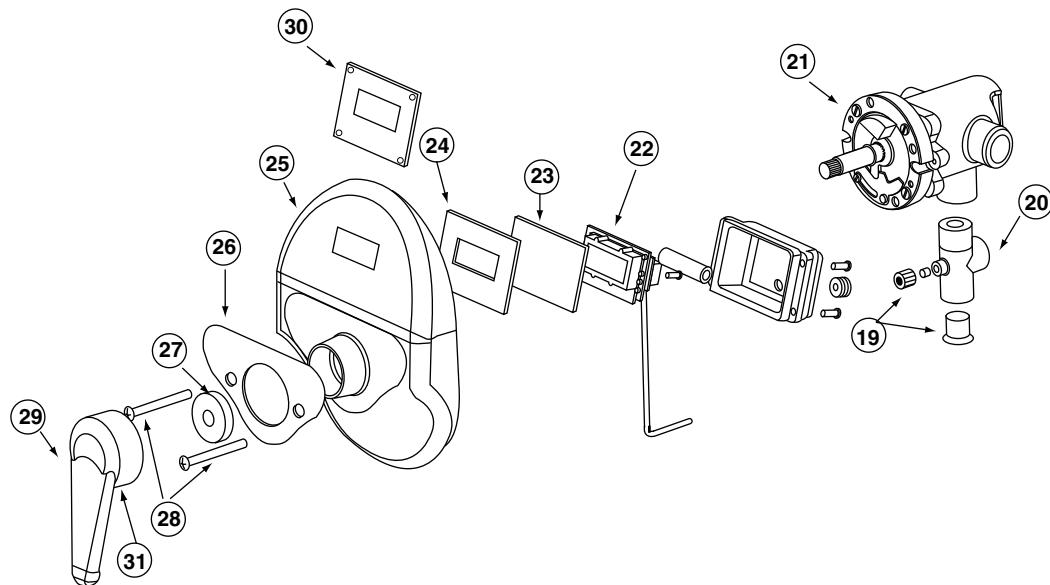

**Series 473 VisuGuard LCD Pressure equalizing mixer.
Poppet-type construction. Adjustable maximum temperature stop.**

Item	Part Description	Kit/Part No.	Quantity	Material
19	Nut, Ferrule, and 5/8" Sweat Plug	473-044	1	Brass & Copper
20	Probe Fitting	N/A		Brass
21	3 Port Mixer with Probe Fitting	473-033	1	Brass
22	Temperature Display with Probe	473-039		Various
23	Display Lens	473-041	1	Lexan
24	Gasket Display	473-041	1	Foam
25	Cover Plate	473-038	1	Chrome Plated Metal
26	Graphic Insert 473-043	1		Polycarbonate
27	Stem Gasket	473-045	1	Foam
28	Cover Plate Screws (Powder Coated)	473-042	10	Stainless
29	Handle & Set Screw	473-035	1	Chrome Plated Metal & Stainless
30	Window Plate for Non-Electronic Model N473 & N474	473-028	1	Chrome Plated Metal
31	Set Screw	088-200	1	Stainless Steel

VisuGuard LCD Kits

Kit/Part No.	Description	Includes:
473-035	Handle Kit	Handle and Set Screw
473-037	Stem Extension Kit	Stem Extension, (2) Long trim plate screws
473-038	Cover Plate Kit	Cover Plate, Graphic Insert, Screws and Gaskets
473-039	Temperature Display Kit	Electronic Display (F /C), Housing, Lens and Gasket
473-041	Lens Kit	Lens and Gasket
473-042	Coated Screw Kit	(10) Powder Coated Screws
473-043	Graphic Insert Kit	Graphic Insert
473-044	Installation Kit	Cover Plate Gasket, Stem Gasket, Compression Nut, Ferrule, and Plug
473-045	Gasket Kit	Cover Plate Gasket, Stem Gasket, and (2) Coated Screws

SERVICING

1. Remove the dial assembly and handle. See page 3 for relationship of parts. Close checkstops or upstream valves. Unscrew four bonnet assembly screws and remove bonnet assembly by gently pulling on stem. Remove discs, O-rings, seals, and springs from chamber.
2. **TO REMOVE THE BALANCE CHAMBER**, using a balance chamber extraction tool (Part No. 401-202) is highly recommended. To use the extraction tool, follow instructions below:
 - a. Insert hooked ends of extraction tool into HOT and COLD outlet ports of the balance chamber (see **Figure 4** below).

Figure 4 – BALANCE CHAMBER REMOVAL

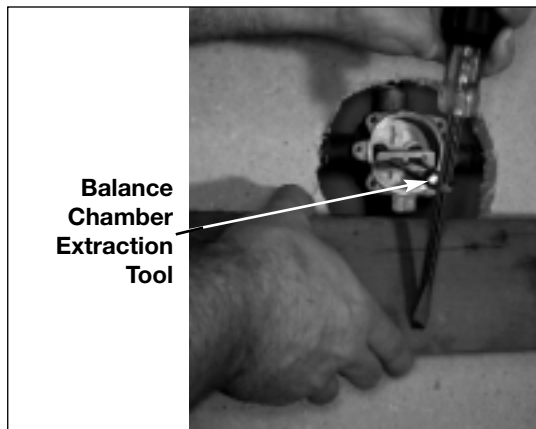

- b. Insert screwdriver down through end of extraction tool.
 - c. Place a wood or plastic block (do *not* use metal) between screwdriver and valve body. Firmly ease screwdriver away and downward, using wood for added leverage as cartridge is gradually pulled out.
3. Replace necessary items and reassemble. Place a small amount of silicone gel on the O-rings only.
 4. **CAUTION:** Do not pinch cartridge O-rings during assembly.
 5. Replace bonnet with new bonnet gasket. Proceed to step 6 to reset maximum temperature setting.

MAXIMUM TEMPERATURE SETTING

6. **MAXIMUM TEMPERATURE SETTING** (refer to **Figure 5**). This must be set on the job and following any maintenance or servicing to the valve. Mixer is factory set to pass full HOT water.
 - a. Loosen adjustment stop screw (do not remove). Gradually rotate stem counterclockwise to get desired maximum water temperature. (Maximum Temperature Stop will rotate along with the stem when the stem is rotated.)
 - b. Once stem has been rotated to desired temperature, slide adjustment stop clockwise until fin on adjustment stop touches the maximum temperature stop.
 - c. While holding adjustment stop in place, tighten adjustment stop screw.
 - d. Replace handle. Confirm maximum temperature has been set properly by operating the valve using the handle.

CAUTION: Adjustment stop must be present for proper operation.

Figure 5 – MAXIMUM TEMPERATURE SETTING

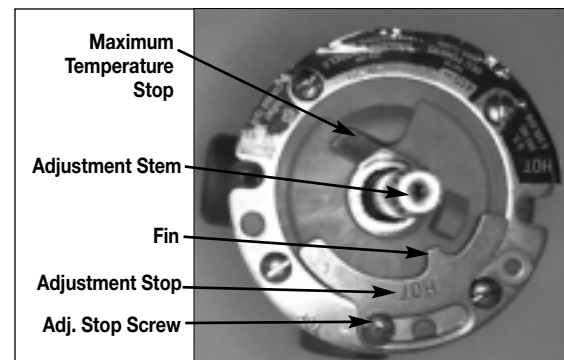

BATTERY REPLACEMENT

1. Remove Handle and Cover Plate.
2. Remove thermistor (temperature probe) by loosening small nut on probe fitting (item 20).
3. Remove electronics enclosure (black) on back of cover plate (attached with four screws).
4. Once enclosure is removed, **carefully** remove lens and electronic LCD display. Battery and battery holder are located on back side of display.
5. Remove and replace battery (AAA alkaline).
6. Reverse procedure to reassemble.

Note: See **Figure 7** for proper installation of temperature probe.

Figure 6

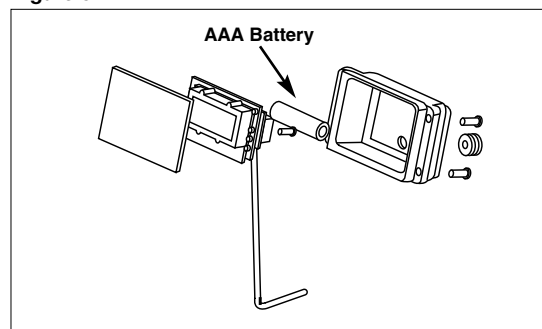
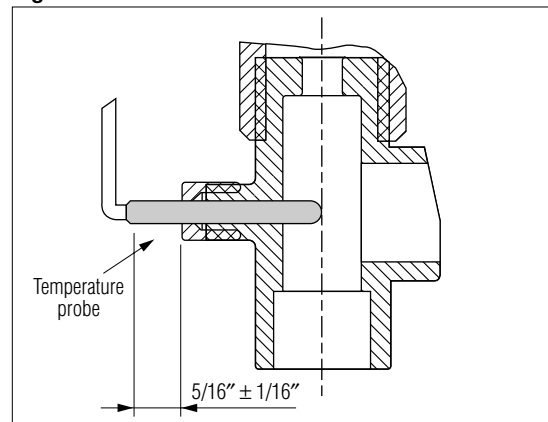

Figure 7



CALIFORNIA PROPOSITION 65 WARNING

WARNING: This product contains chemicals known to the State of California to cause cancer and birth defects or other reproductive harm.

(Installer: California law requires that this warning be given to the consumer.)

For more information: www.wattsind.com/prop65

WARRANTY INFORMATION

Powers warrants that the equipment manufactured by it is free from defects in material and workmanship and, without charge, equipment found to be defective in material and workmanship will be repaired, or at Seller's option, replaced F.O.B. original point of shipment, if written notice of failure is received by Seller within one (1) year after date of shipment, provided said equipment has been properly installed, operated in accordance with Seller's instructions, and provided such defects are not due to abuse or chemical decomposition by chemical or galvanic action. This express warranty is in lieu of and excludes all other warranties, guarantees, or representations, express or implied. There are no implied warranties of merchantability or of fitness for a particular purpose. The Seller assumes no responsibility for repairs made on Seller's equipment unless done by Seller's authorized personnel, or by written authority from the Seller. The Seller makes no guarantee with respect to material not manufactured by it.

POWERS
A WATTS INDUSTRIES CO.

© Reprinted March 2002 **Powers, a Watts Industries Co.**

USA Phone: 800.669.5430

www.powerscontrols.com

Canada Phone: 888.208.8927