

DESCRIPTION

The BILTMORE is a pressure-balancing mixer which delivers a predetermined mix of hot and cold water by compensating for pressure fluctuations in the hot and cold water supplies.

The BILTMORE features a poppet design valve as part of a replaceable balancing cartridge. The poppet-type construction offers two distinct advantages: It will not stick due to lime build-up or foreign particles in the supply water, and it has a quick reaction time. The adjustable maximum temperature stop prevents overadjustment of the handle.

Safety feature: Should either supply fail, the BILTMORE closes either hot or cold supply water, to prevent a continued spray of all hot or all cold water.

SPECIFICATIONS

Capacity	4.6 gpm @ 45 psi [15 L/min @ 310 kPa Differential]
Maximum Static Pressure	125 psig [862 kPa]
Maximum Inlet Temperature	180°F [82°C]
Inlet and Outlet Sizes	1/2" sweat or NPT thread
Rough-in Guide	All Models
Handle Rotation Stop	All Models
Compliance	ASSE 1016
Certified	CSA B125

APPLICATION

The BILTMORE is particularly recommended for shower and shower/tub installations in hotels, motels, high-rise apartments, condominiums, and single-family housing.

OPERATION (See Figure 1)

Pressure balancing valve (Type P) senses incoming water pressures and compensates for fluctuations in either to stabilize outlet temperature (1). The entire balancing poppet assembly is contained in a Celcon chamber (2). This chamber is replaceable as a complete cartridge. The hot and cold are mixed by the action of the mixing plate (3). As the temperature adjustment stem is rotated from shutoff to maximum hot water discharge temperature, the mixing plate passes the required proportion of hot and cold water to produce the desired water temperature. With the adjustment stem in its full clockwise position, shutoff is obtained by closing off both supplies.

The maximum temperature limit stop (located on the bonnet) allows the user to set the desired maximum discharge temperature. This mixer does not compensate for supply water temperature changes, so any variation in the water temperature will affect the control point and the maximum discharge temperature setting.



CAUTION: Maintenance of the unit requires resetting of the maximum temperature adjustment stop. As inlet conditions (pressures and temperatures) vary from site to site and season to season, failure to properly adjust the maximum temperature adjustment stop can result in excessive hot water delivery.

Figure 1

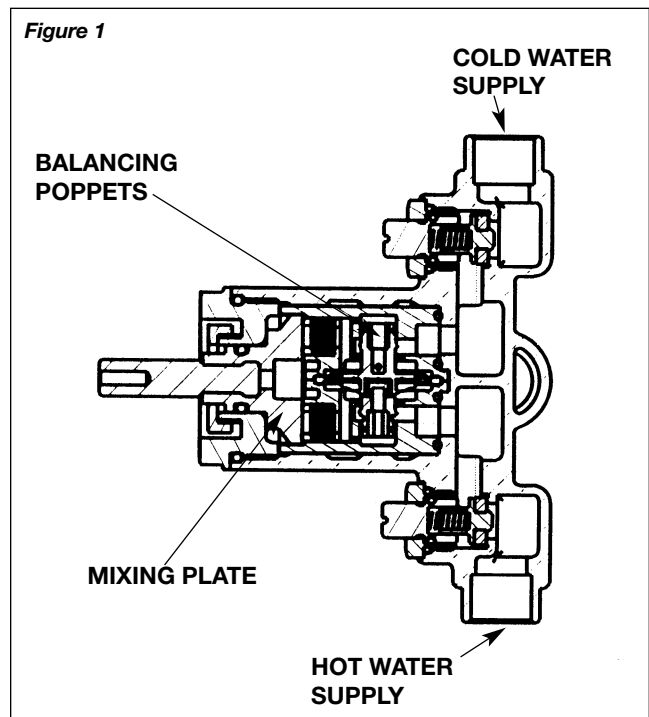

MAINTENANCE/TROUBLESHOOTING

What to look for if:

- 1. The flow of water is less than desired.**
 - a. Valves upstream from supply not full open
 - b. Low inlet water supply pressure(s)
 - c. Accumulation of lime deposits in hot water pipes, restricting flow of hot water
 - d. Showerhead clogged
 - e. Low hot water supply temperature
 - f. Checkstops obstructed or jammed
- 2. The flow of water is completely shut off.**
 - a. Valves upstream from supply completely closed
 - b. Failure of hot or cold water supply pressure, the mixer is designed such as to restrict the flow of water on hot or cold water supply failure
 - c. Checkstops are closed
- 3. The flow is untempered hot or cold water.**
 - a. Hot water supply temperature is too low
 - b. Diaphragm is ruptured; replace with new balance chamber
- 4. The flow of water continues after mixer is shut off.**
 - a. Worn shutoff discs; replace shutoff discs
 - b. Foreign particles on mixing plate causing scratches; replace stem and plate
 - c. Worn discs on inlet ports of balancing cartridge; replace discs
- 5. The maximum temperature is low.**
 - a. Accumulation of lime deposits in hot water pipes restricting flow of hot water
 - b. Concealed maximum temperature stop is not at desired adjustment point
 - c. Hot water supply temperature is too low
- 6. The valve opens with hot water flow rather than cold water flow.**
 - a. Inlet water supplies are connected to the wrong ports; see instructions below on reversed inlets.

REVERSED INLETS

Cold into hot, hot into cold

If *reversed inlets* are required due to back-to-back installation, close check stops. Remove High Temperature Limit Stop. Unscrew bonnet. Rotate stem 180. **The word "TOP" stamped on stem must face down toward tub outlet.** Reinstall bonnet. Place High Temperature Limit Stop on bonnet.

NOTE: Hot and cold inlets should be re-identified for reversed inlets to avoid confusion during future maintenance.

SERVICING

To service mixer, remove handle and dial assembly. Shut off water supply at checkstops. Remove sleeve and O-ring, unscrew bonnet, and remove stem.

To remove balance chamber, use needle-nose pliers. Pull straight out.

Reassemble; Apply silicone grease to stem assembly (15) at O-ring (14) and mixing plate face. Also apply silicone grease to outlet seal (16). Be certain "TOP" stamped on stem is facing up. Screw bonnet onto body; tighten to 75 in.-lbs. Place O-Ring on bonnet. Slide sleeve over O-Ring. Turn on water at checkstops. Replace dial assembly and handle.

To service checkstops, turn off water supplies upstream of mixer. Unscrew checkstop bonnet nut and remove plunger. Replace items as required.

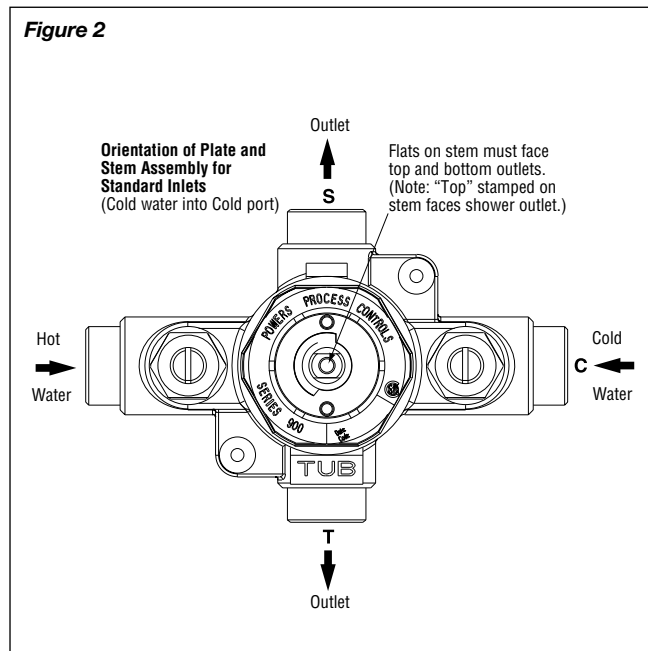

PARTS

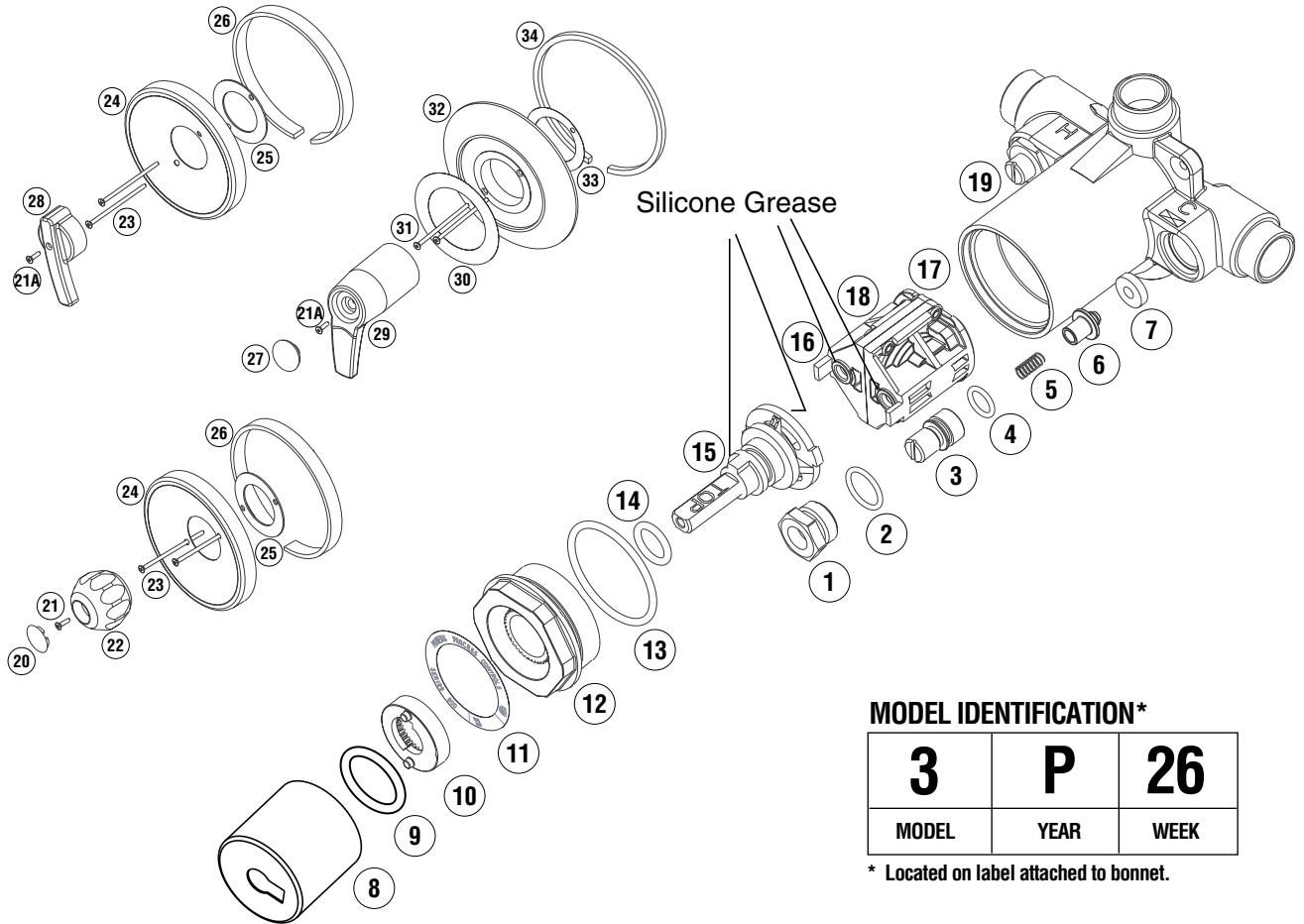

PARTS LIST

Item	Part No.	Description	Material	Kit No.***	Item	Part No.	Description	Material	Kit No.***
1	900-213	Bonnet Nut	Brass	900-050	19		Body	Bronze	N/A
2	084-029	O-Ring	Buna-N	900-028, 050	20	900-140	Plug Button	Acrylic	900-035
3	900-214	Check Stem	Brass	900-050		900-142	Insert		900-035
4	084-030	O-Ring	Buna-N	900-025, 050	21	800-161	Screw 8-32 x 5/8"	Brass	900-035
5	900-215	Spring	S.S.	900-050	21A	800-164	Screw 8-32 x 5/8"	Brass	900-105, 036
6	900-212	Poppet	Brass	900-050	22	900-019C	Knob	Acrylic	900-035
7	800-061	Disc	Buna-N	900-028, 050	23	080-026	Screw 8-32 x 3 1/2"	Brass	900-040, 102
8*	800-015H	Sleeve	C.P. Brass	900-269	24	900-020A	Round Dial Plate	S.S.	900-040
9	084-041	O-Ring	Buna-N	900-028	25	800-020	Gasket	Buna-N	900-040
10	900-220	Limit Stop	Celcon	900-032	26	401-229	Gasket	Buna-N	900-040
11	900-137	Name Plate		900-032	27	900-096	Plug Button	ABS	900-105
12	900-219	Bonnet		900-032	28	900-070	Lever Handle	Cast	900-036
13	084-032	O-Ring	Buna-N	900-028, 032	29	900-091	Handle	ABS	900-105
14	084-033	O-Ring	Buna-N	900-028, 032	30	900-095	Insert	Mylar	900-102
15	900-231	Stem Assy.		900-032	31	080-026	Screw 8-32 x 3 1/2"	Brass	900-040, 102
16	900-197	Outlet Seal		900-028, 032	32	900-090	Trim Plate	C.P. ABS	900-102
17	084-031	O-Ring	Buna-N	900-028, 032	33	900-093	Sleeve Gasket		900-102
18	900-240	Cartridge	Celcon	900-032	34	900-094	Trim Gasket		900-102

* 900-132 in Model P910.

N/A = Part not available.

** Plug button (#900-140), insert (#900-142), and lucite handle (#900-019) are included in Lucite Handle Assembly Kit #900-035.

*** Parts must be ordered by Kit number, not by individual part number .

TROUBLESHOOTING & REPAIR KITS

Description	Troubleshooting	Repair Kit No.
Gasket and Disc Replacement (mixer & checkstops)	<ul style="list-style-type: none"> Water leaks at valve stem and/or bonnet. Water leaks at valve shut-off. Water leaks at checkstop. 	900-030 Models 1 & 2* 900-028 Model 3
Internals Replacement	<ul style="list-style-type: none"> With mixer handle in MID position, hot water flows with cold water checkstop closed or cold water flows with hot water checkstop closed. 	900-031A Model 1 900-031 Model 2 900-032 Model 3
Checkstop Replacement	<ul style="list-style-type: none"> Checkstop will not completely shut off. 	900-049 Models 1 & 2 900-050 Model 3
Conversion from 800 Lever Handle to 900 Lever Handle	<ul style="list-style-type: none"> 800 handle will not operate properly. 	800-098**
Conversion from 800 Lucite Knob to 900 Lucite Knob	<ul style="list-style-type: none"> 800 handle will not operate properly. 	800-099**

* Model 1—Use white TFE gasket; Model 2—Use black Viton A O-ring.
 ** Replacement of Biltmore 800 handle/stem, escutcheon, or cartridge upgrades the valve to a Biltmore 900 Model 2.

ADDITIONAL KITS

ABS Lever Handle Kit (Model 905)	900-105
Faceplate Assembly (Model 905) (chrome finish)	900-102
Faceplate Assembly, Round	900-040
Plug Button with Insert for Lucite Handle	900-140
Plug Button Bulk Pack (25 pieces of 900-140)	900-140BP
Stem Extension Kit	900-109
Thin Wall Mounting Kit	900-119
Vandal-Proof Screws (for handle and faceplate)	900-034

MAXIMUM TEMPERATURE SETTING

The maximum temperature setting must be set on the job. Rotate stem to desired maximum temperature but in no case greater than 46°C [115°F]. High temperature limit stop is located on the bonnet. remove it, and place it back toughing tab on stem.

The maximum temperature setting must be readjusted if the hot water supply temperature is changed, and **also seasonally to compensate for changes in the cold water supply temperatures.**

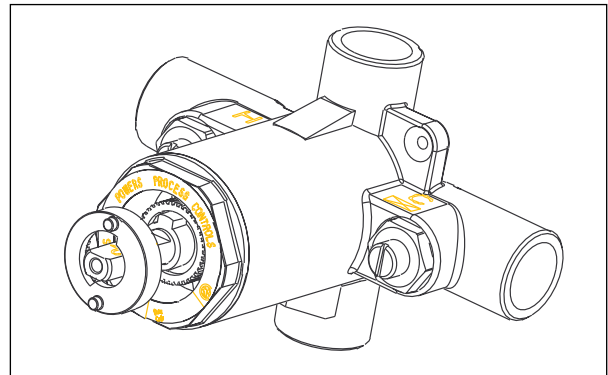

CALIFORNIA PROPOSITION 65 WARNING
WARNING: This product contains chemicals known to the State of California to cause cancer and birth defects or other reproductive harm. (California law requires this warning to be given to customers in the State of California.)
 For more information: www.wattsind.com/prop65

WARRANTY INFORMATION

Powers warrants that the equipment manufactured by it is free from defects in material and workmanship and, without charge, equipment found to be defective in material and workmanship will be repaired, or at Seller's option, replaced F.O.B. original point of shipment, if written notice of failure is received by Seller within one (2) years after date of shipment, provided said equipment has been properly installed, operated in accordance with Seller's instructions, and provided such defects are not due to abuse or chemical decomposition by chemical or galvanic action. This express warranty is in lieu of and excludes all other warranties, guarantees, or representations, express or implied. There are no implied warranties of merchantability or of fitness for a particular purpose. The Seller assumes no responsibility for repairs made on Seller's equipment unless done by Seller's authorized personnel, or by written authority from the Seller. The Seller makes no guarantee with respect to material not manufactured by it.

 A WATTS INDUSTRIES CO.	© 2003 Powers, a Watts Industries Co. USA Phone: 1.800.669.5430 • Fax 1.877.459.3440 Canada Phone: 1.888.208.8927 • Fax 1.888.882.1979 www.powerscontrols.com
---	--