

VALVE DESCRIPTION

The Powers #11 Stainless Steel Trim Regulator is a self-actuating control valve which automatically controls the temperature of a fluid without the use of external power. The SST Regulator is specifically designed for high pressure steam applications requiring positive shutoff. Adjust the set point and the rugged self-operating #11 Regulator controls the flow of heating or cooling medium (water or steam) to maintain a constant temperature.

The instrument has a vapor pressure thermal system containing a thermally responsive fluid. This thermal system rapidly senses temperature changes at the bulb and accordingly positions the valve plug, to regulate the flow of the heating or cooling medium to maintain a desired temperature. The thermal system features a two-ply brass bellows with six reinforcing ribs on the bellows head and thick capillary tubing walls to ensure long operating life.

The Powers #11 ST Regulator features:

- Stainless steel valve plug and seat ring withstand high temperatures
- Tight shutoff when the valve is closed
- A valve stem of highly polished corrosion resistant grade 316L stainless steel to decrease friction and reduce hysteresis
- An adjusting nut mounted on ball bearings and a set point adjusting rod to ease set point adjustments
- A set point reference scale to aid temperature adjustments

TABLE OF CONTENTS

Valve Description	1
Operation	1
Applications	2
Specifications	2
Water Capacities	3
Sizing and Selection	3
Steam Capacities	4
Product Identification	5
Installation	5
Maintenance	6
Valve Seat Removing Tool	8
Preventive Maintenance	9
Troubleshooting	9, 16
Dimensions	10
Parts List	12
Accessories	14
Temp. Ranges/Bulb Sizes	14
Order Code	15
Warranty Information	16

OPERATION

A bulb is connected to a bellows containing a thermally responsive fluid. The bulb is inserted into the fluid you are trying to control (process fluid) to sense its temperature. The Regulator set point is adjusted to allow sufficient flow of heating or cooling medium (water or steam) through the valve to keep the process fluid at the desired temperature.

Direct Acting (heating application)

(A) When the temperature of the process fluid drops below the set point, the temperature of the thermally responsive fluid decreases, which decreases the vapor pressure in the bulb/bellows. The force of the resulting vapor pressure is less than the spring force, so the bellows contract and the spring extends, which raises the valve plug up from its seat. This increases the flow of the heating medium (water or steam), which raises the temperature of the process fluid.

(B) As the process fluid temperature increases toward or beyond the desired set point, the temperature of the thermally responsive fluid in the bulb increases, which causes the vapor pressure to increase. This expands the bellows, compresses the spring, and moves the valve plug down and closer to its seat, to reduce or stop the flow of the heating medium.

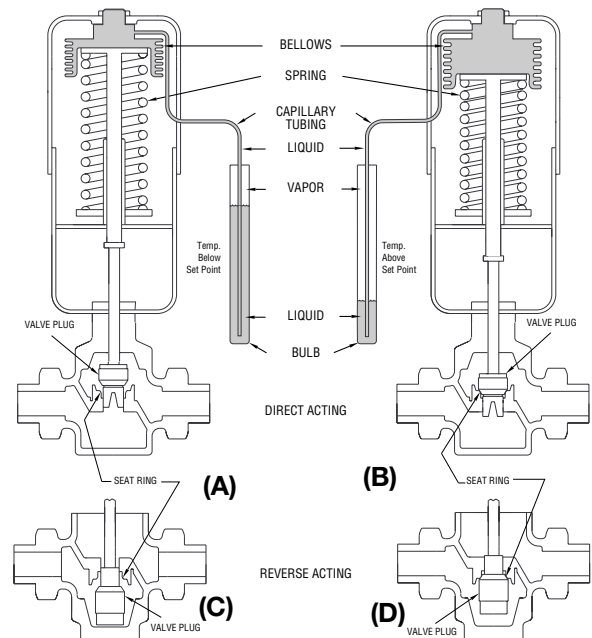

Reverse Acting (cooling application)

(C) When the temperature of the process fluid rises toward or above the set point, the temperature of the thermally responsive fluid increases, which increases vapor pressure in the bulb/bellows. The resulting force of the vapor pressure is greater than the spring force, so the spring contracts and the bellows expand to push the valve plug downward, away from its seat. This increases the flow of the cooling medium, which lowers the temperature of the process fluid.

(D) As the process fluid temperature decreases toward or below the desired set point, the temperature of the thermally responsive fluid decreases, causing the vapor pressure to decrease. This contracts the bellows and expands the spring to pull the valve plug up towards its seat, to reduce or stop the flow of the cooling medium.

SPECIFICATIONS

Physical

Valve Sizes: 1/2"A, 1/2"B, 1/2"C, 1/2"D, 1/2", 3/4", 1" (NPT)

Body Material: Bronze

Body Rating: ANSI Class 250

Connections: Double Female Unions with Pipe Thread

Style: Single Seat, Stainless Steel Trim, V-Port

Valve Plug Travel: See Dimensional Data on page 10

Effective Bellows Area: 7.8 in² (50.3 cm²)

Maximum Body Temperature: 400°F (204°C)

Operating

Temperature Range: See Order Code on page 15

Controlled Medium: Steam, water and fluid not corrosive to stainless steel and bronze

Maximum Differential Pressure: See Tables on pages 3 & 4

Maximum Allowable Overheat Temperature: 25°F (14°C) above range

Maximum Well Safe Pressures: See Table on page 10

Maximum Body Pressure: 250 psi (1723.75 kPa)

Shipping Weight: See Table 11

Flow Characteristics: Modified Parabolic

Shutoff Class Rating: ANSI Class III (Leakage 0.1% of rated valve capacity)

APPLICATIONS

Powers #11 Regulators are used to automatically control the temperature of a fluid, specifically in processes requiring high pressure steam (up to 200 psi). The self-actuated Regulator can easily be installed in any convenient location. Among its applications are: hot water systems, fuel oil heaters, control for jacket water cooling for air compressors, dairy equipment, and many industrial processes. Below are two typical applications.

Quench Tank Application

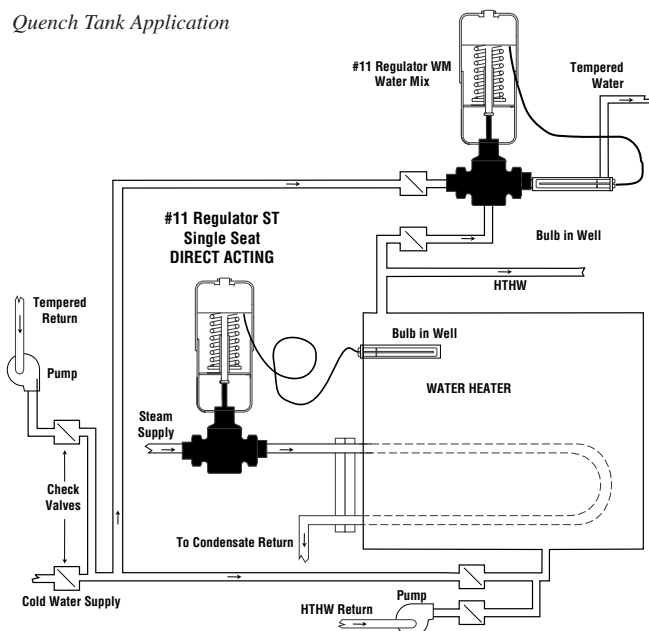

Jacket Water Cooling Application

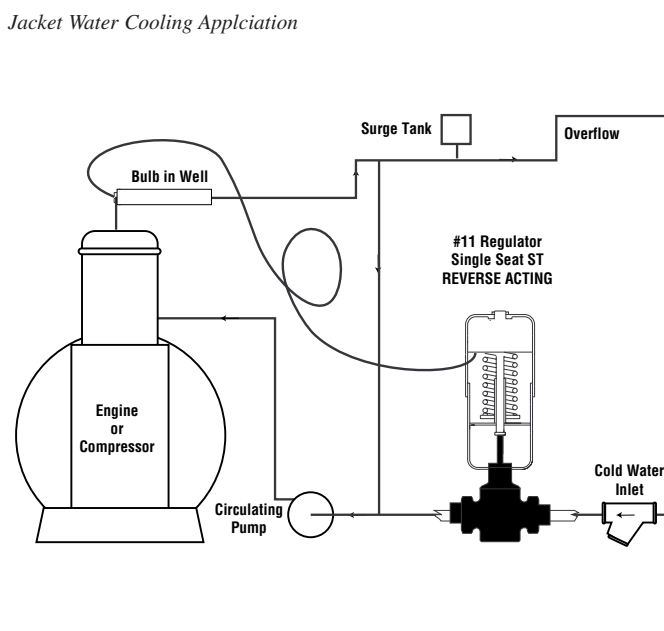

SIZING AND SELECTION

Proper sizing of the Regulator is essential for correct system operation. An undersized Regulator will not allow sufficient flow at maximum load. An oversized Regulator may cycle and will not utilize the full valve stroke for efficient modulation of flow. This results in poor control and shortened valve life (quicker deterioration of valve plug and seat). For these reasons, the correct sizing of the Regulator for actual expected conditions is considered essential for good control.

NOTE: Select a bulb (see chart on page 14) that has the set point in the upper third of the temperature range for best valve performance.

Size the #11 Regulator for actual rather than maximum conditions. DO NOT size according to pipe size; piping systems

are designed for different criteria than process controls. Refer to Powers document **AE-1—“Valve Selection and Sizing”**—for further recommendations.

Maximum Operating Pressure Differential (differential for fluid flow): In order for the process medium to flow, a pressure drop must exist across the valve. “Pressure differential” is the difference in valve pressure between the inlet and outlet under flow conditions. The greater the differential, the greater the flow at any given plug position.

Though the regulator should be sized for actual conditions, you need to know the available differential at maximum flow. For optimum control, take as much differential as possible across the valve.

WATER CAPACITIES

Use a pressure drop of at least 25% of inlet pressure when sizing valves for water applications.

CAUTION: Do not exceed maximum pressure differentials for given valve sizes. The **maximum differential** is the pressure the valve has against it at shutoff. Too large a differential can cause valve chatter and/or prevent shutoff.

WATER CAPACITIES --- GPM

Valve Size	Available Sizing Pressure Differential --- PSI																Maximum Δp (psi) Liquid
	Cv	2	4	6	8	10	15	20	25	30	40	50	60	80	100	125	
1/2A	0.25	0.4	0.5	0.6	0.7	0.8	1	1.1	1.3	1.4	1.6	1.8	1.9	2.2	2.5	2.8	200
1/2B	0.5	0.7	1	1.2	1.4	1.6	1.9	2.2	2.5	2.7	3.2	3.5	3.9	4.5	5	5.6	200
1/2C	1	1.4	2	2.4	2.8	3.2	3.9	4.5	5	5.5	6.3	7.1	7.7	8.9	10	11	200
1/2D	2	2.8	4	4.9	5.7	6.3	7.7	8.9	10	11	13	14	15	18	20	22	200
1/2"	2.6	3.7	5.2	6.4	7.4	8.2	10	12	13	14	16	18	20	23	26	29	200
3/4"	4.6	6.5	9.2	11	13	15	18	21	23	25	29	33	36	41	46	51	140
1"	11	16	22	27	31	35	43	49	55	60	70	78	85	-	-	-	70

WATER CAPACITIES --- L/S

Valve Size	Available Sizing Pressure Differential --- kPa																Maximum Δp (kPa) Liquid
	7	15	30	45	60	75	100	125	150	200	250	350	450	550	650	750	
1/2A	0.02	0.02	0.03	0.04	0.05	0.05	0.06	0.07	0.07	0.08	0.09	0.11	0.13	0.14	0.15	0.16	1379
1/2B	0.03	0.05	0.07	0.08	0.09	0.1	0.12	0.13	0.15	0.17	0.19	0.22	0.25	0.28	0.31	0.33	1379
1/2C	0.06	0.09	0.13	0.16	0.19	0.21	0.24	0.27	0.29	0.34	0.38	0.45	0.51	0.56	0.61	0.66	1379
1/2D	0.13	0.19	0.26	0.32	0.37	0.42	0.48	0.54	0.59	0.68	0.76	0.9	1.02	1.13	1.22	1.32	1379
1/2"	0.17	0.24	0.34	0.42	0.48	0.54	0.62	0.7	0.76	0.88	0.99	1.17	1.32	1.46	1.59	1.71	1379
3/4"	0.29	0.43	0.61	0.74	0.86	0.96	1.11	1.24	1.35	1.56	1.75	2.07	2.34	2.59	2.82	3.03	965
1"	0.7	1.02	1.45	1.77	2.05	2.29	2.64	2.95	3.24	3.74	4.18	4.94	5.61	-	-	-	483

PRODUCT IDENTIFICATION

A red label should be on the front face of the thermal system, *Figure 1*. This label contains information required to properly maintain, service and order parts for this product.

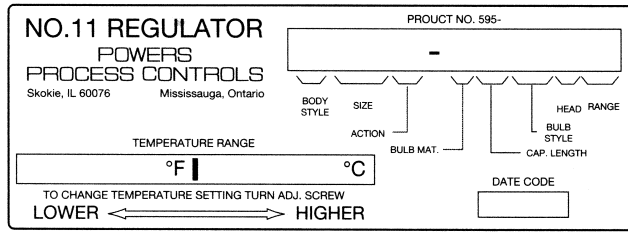

1. PRODUCT LABEL

If there is no label, look for a white label on the inside of the thermal system (*Figure 2A*) legs or the valve body vertical yoke (*Figure 2B*). When replacing the original thermal assembly or valve body, secure the old red label onto the valve or thermal system or ink the number onto the body.

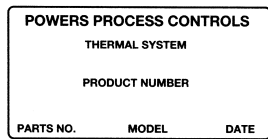

2A. THERMAL SYSTEM LABEL

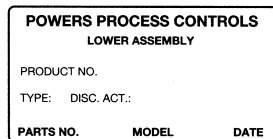

2B. VALVE BODY LABEL

INSTALLATION

TOOLS NEEDED

- Straight slot screwdriver
- 5/16" open end wrench
- 3/8" open end wrench
- 7/16" open end wrench
- 1-3/8" open end wrench
- Pliers

POSITION VALVE

1. To insure proper system operation, thoroughly flush all piping and valves to rid them of all scale, dirt and debris.
2. Select valve location with sufficient clearance to allow maintenance. Install valve in line. The direction of the arrows on the valve body must match the direction of the water or steam flow.

For best results, we recommend installing the valve in a horizontal line, and in the upright position with bellows head above valve. The valve may also be installed in any position within 90° of upright.

INSTALL BULB

3. *Figure 3A* shows proper bulb orientation. *Figure 3B* shows the special bulb needed for upwards vertical positioning.
4. *Figure 4*. For any position, fully immerse the bulb in the flow of the medium.

These instructions are for D style bulbs - for installation of other styles, refer to tag attached to bulb.

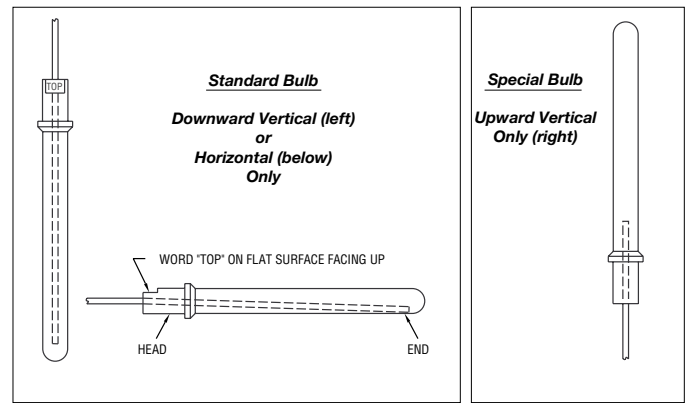

3A. BULB ORIENTATION

3B. SPECIAL BULB

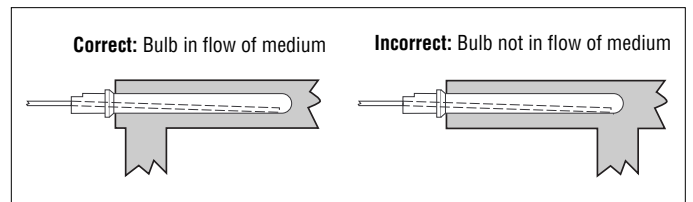

4. BULB POSITIONS

5. **Without a well:** Remove bushing from the bulb and screw it into the tank. Insert the thermostatic bulb through the bushing and tighten the union nut.

With a well: Do not use bushing. Screw well into tank, insert bulb directly into well, and tighten union nut.

ADJUST CAPILLARY TUBING

6. Coil the extra capillary, and position away from regulator operation where it is subjected to room temperature only.

WARNING: DO NOT kink, cut, sever or file the tubing. DO NOT disconnect tubing from bulb or bellows assembly. This can render the thermal system inoperable and result in severe process overheating.

ADJUST SET POINT

All regulators are factory set to control near mid-range operating temperature.

7. When adjusting the set point, make certain the heating medium is flowing through the valve and is at the operating pressure of the system.

8. *Figure 5*. Make all set point temperature changes by inserting the temperature adjustment rod [15] (included with product) into one of the holes on

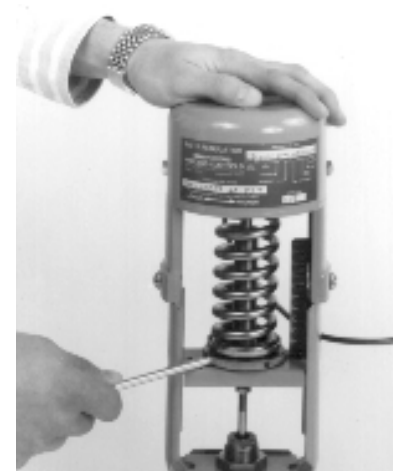

5. ADJUSTING SET POINT

the adjusting nut assembly. (Use the temperature adjustment setting scale only for reference.)

To Raise the set point: Turn rod left to right (counter clockwise from top).

To Lower the set point: Turn rod right to left (clock wise from top).

MAINTENANCE

Numbers in brackets [#] refer to part numbers on pp. 12 & 13.

DA: To replace the valve seat only

See page 8 for construction of the Seat Ring Tool.

1. Before disassembly, the **bulb must be cooled** 30°F (16°C) below the lowest point on the thermal system range, and **flow through the valve must be stopped**.
2. *Figure 5.* Relieve all pressure on the spring by turning adjusting nut assembly [31] fully right to left (clockwise from top).
3. *Figure 6.* Loosen lock nut [11] with 1-3/8" open end wrench.

Use the 1-3/8" wrench to unscrew bonnet [20] from valve body [26]. DO NOT ALLOW the regulator top to rotate.

Lift up regulator top.

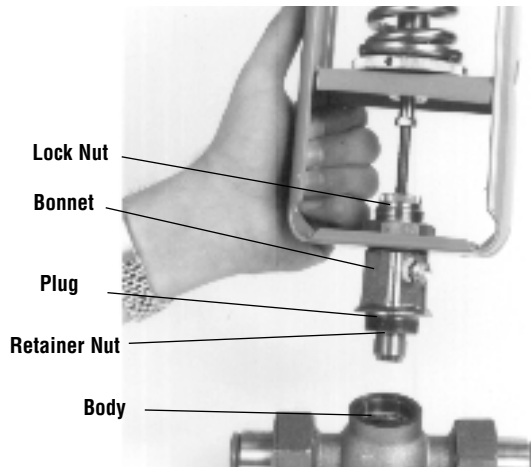

6. LIFT OFF REGULATOR FROM VALVE

4. *Figure 11.* Insert Seat Ring Tool into valve body. Make sure the bit engages the slots provided in the seat ring [25].
5. Turn counterclockwise to remove.
6. After replacing, make certain the new seat ring is tightly screwed into place.
7. Assemble in reverse order.

DA/RA: To fully disassemble regulator from valve

1. Before disassembly, the **bulb must be cooled** 30°F (16°C) below the lowest point on the thermal system range, and **flow through the valve must be stopped**.
2. *Figure 5.* Relieve all pressure on the spring by turning adjusting nut assembly [31] fully right to left (clockwise from top).

3. *Figure 7.* Remove housing bolts [6] and nuts [7] and temperature adjustment setting scale [8] and lift off thermal system [1] (housing, bellows, capillary, and bulb).



7. REMOVE HOUSING AND THERMAL SYSTEM

4. *Figure 8.* Using one 3/8" wrench and one 5/16" wrench, carefully loosen and remove piston plate assembly [2,3] from the stem extension [4]. Lift off spring [19].

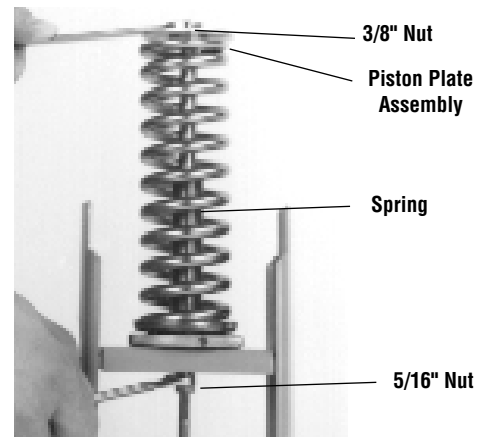

8. REMOVE PISTON PLATE/SPRING

5. *Figure 9.* Use 1-3/8" wrench to unscrew lock nut [11] and lift off the yoke and bridge assembly [9].

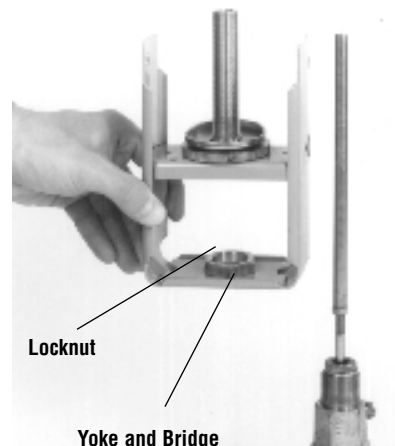

9. LIFT OFF YOKE AND BRIDGE

DA/RA: To replace valve plug and seat

Follow steps 1-5, **To fully disassemble regulator from valve.**

6. **DA:** *Figure 10A.* Unscrew bonnet [20] from valve body [26]. Lift off stem assembly and bonnet. Remove retainer nut [22]. Replace plug [24].

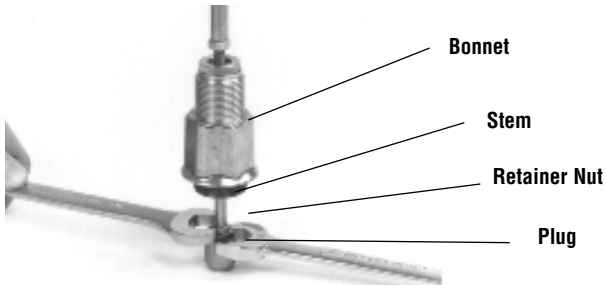

10A. (DA) REMOVE PLUG RETAINER NUT AND PLUG

RA: *Figure 10B.* Remove valve cap [29] from the bottom and the bonnet [20] from the top of the valve body [26]. Remove stem retainer [22] and valve plug [24], then the stem assembly [30]

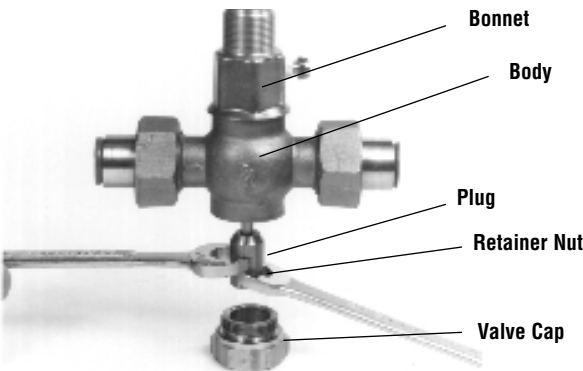

10B. (RA) REMOVE VALVE CAP/REMOVE STEM AND PLUG

7. *Figure 11.* Insert Seat Ring Tool into valve body. Make sure the bit engages the slots provided in the seat ring [25]. Turn counterclockwise to remove.

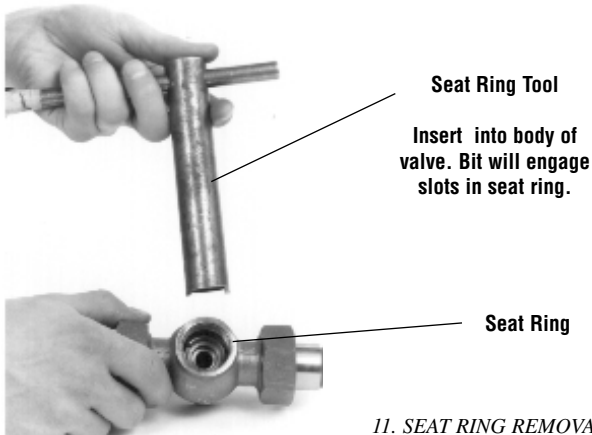

11. SEAT RING REMOVAL

8. After replacing, make certain the new seat ring is tightly screwed into place.
9. Assemble in reverse order.

DA/RA: To replace packing

Follow steps 1-5, **To fully disassemble regulator from valve.**

6. Use the 5/16" wrench on the flats of the stem extension [4] and the 7/16" wrench on the hex nut [12] to loosen and remove them.
7. Use the 1-3/8" wrench to loosen and remove bonnet [20].
8. Carefully pull out stem assembly [30]. Check the stem. It must have a polished surface that is free of roughness and pitting. Replace any parts if necessary.
9. *Figure 12.* Remove packing gland [14], and all packing components [15a-15e].

Clean packing chamber, taking care not to scratch seating surfaces. Be sure chamber is free of dirt and grease.



12. PACKING COMPONENTS

10. Replace bonnet [20] and stem [30] into valve body.
NOTE: You must replace the bonnet and stem before attempting to insert the packing. Otherwise, you may tear the packing rings.
11. For standard packing kits, install parts as shown in *Figure 11.* Slide part(s) [15e], followed by [15d] and [15c] over the stem. Gently push them into the packing chamber.
NOTE: Some kits do not include all the listed packing parts (see page 12), but the order for part installation is the same.
12. **For EP V-rings,** lubricate the rings first.
Slide each V-ring [15b] over the stem and carefully push it into the packing chamber.
13. Place the packing gland spacer [15a] on top of the bonnet.
14. Thread the packing gland assembly [14] into the bonnet. Tighten the gland assembly against the spacer.
15. With **valve plug firmly seated (Stem fully down for DA, Stem fully up for RA),** screw stem extension [4] to the dimension shown in *Figure 13,* and tighten with hex nut [12].

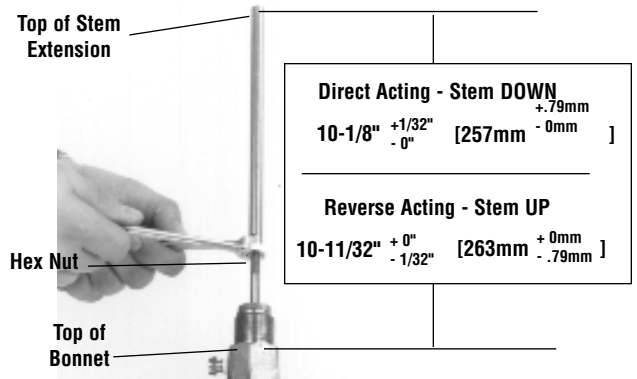

13. STEM EXTENSION REASSEMBLY DIMENSION

16. Assemble the remaining parts in reverse order.

VALVE SEAT RING TOOL

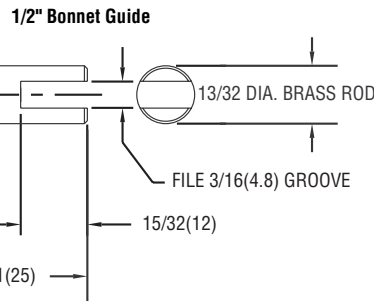
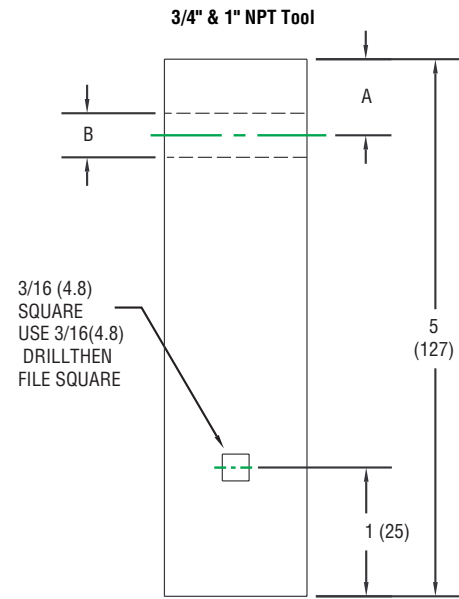
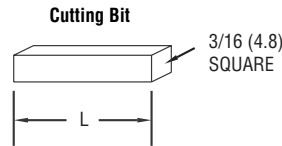
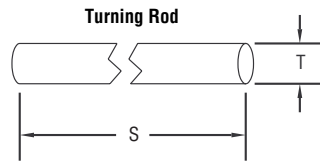
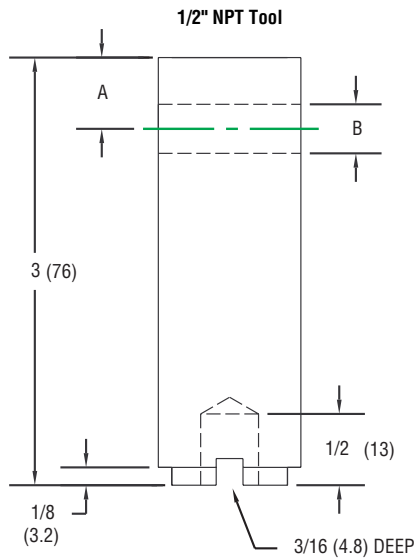

3/4" & 1" Bonnet Guide

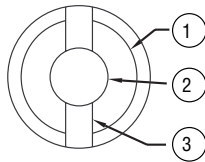
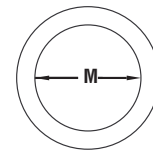

CUTTING 1/2 VALVE TOOL

1. TURN DOWN TO 13/16(48) DIAMETER
2. DRILL 13/32(10) DIAMETER HOLE 1/2(13) DEEP
3. FILE GROOVE 3/16(4.8) WIDE BY 3/16(4.8) DEEP

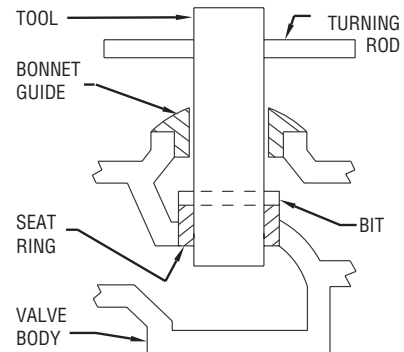

TOOL ASSEMBLY - 1/2" NPT and 3/4" & 1" NPT

1. INSERT CUTTING BIT INTO BODY GROOVE (1/2) or SQUARE HOLE (3/4 & 1).
2. PLACE GUIDE INTO POSITION OVER TOOL BIT AND PRESS INTO BODY.

Valve Seat Removing Tool Dimensions

Valve	Pipe or Rod Size	A (in)	B (in)	Turning Rod		Cutting Bit	Bonnet Guide	
				S (in)	T (in)		Part #	M (in)
1/2"	1" DIA Bar Stock	1/2	11/32	8 to 10	5/16	1 1/16	-	-
3/4"	1/4" Pipe	3/4	9/32	12	1/4	1 13/16	590 134	9/16
1"	1/2" Pipe	1	13/32	12	3/8	1 1/2	590 137	27/32

Valve	Pipe or Rod Size	A (mm)	B (mm)	Turning Rod		Cutting Bit	Bonnet Guide	
				S (mm)	T (mm)		Part #	M (mm)
1/2"	1" DIA Bar Stock	13	9	203 to 254	8	27	-	-
3/4"	1/4" Pipe	19	7	305	6	46	590 134	14
1"	1/2" Pipe	25	10	305	10	38	590 137	21

TESTING THE THERMAL SYSTEM

If the valve is not responding to temperature change, test the thermal system.

1. Stop the flow of fluid through the line.
2. **DA:** Raise the temperature of the bulb above the set point temperature by placing it in a container of hot water. This will cause the plug to fully seat.
RA: Raise the temperature of the bulb above the set point temperature by placing it in a container of hot water. This will cause the plug to fully open.
3. *Figure 14.* With the valve plug seated, use a felt tip pen to mark where the position of the packing gland assembly on the stem.

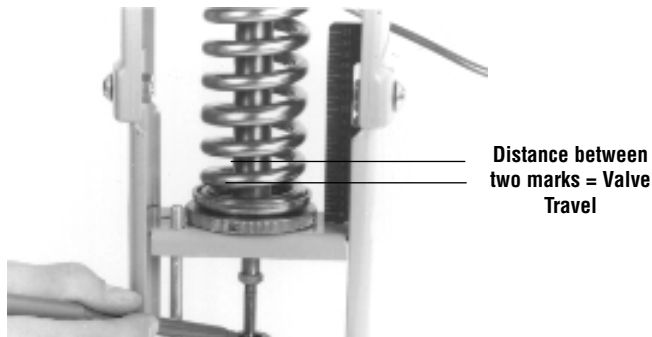

14. VALVE TRAVEL MEASUREMENT

4. **DA:** Place the bulb in a pan of cool water. Cool the bulb 30°F (16°C) below set point so the valve is fully open.
RA: Place the bulb in a pan of cool water. Cool the bulb to or beyond the set point so the valve plug is seated.
5. Use the pen to mark the new position of the packing gland assembly on the stem.
6. The distance between the marks is the valve plug travel. This should correspond with the TRAVEL value in the VALVE DIMENSIONS table on page 10. **No movement or only partial movement indicates the thermal system is defective and should be replaced with a new system.**

PREVENTIVE MAINTENANCE

Once every three months, inspect the Regulator as follows:

1. Visually check for leaks from the valve body joints, piping-to-valve connections, packing and stem areas.
2. Visually check for excessive corrosion on the regulator, including the bellows, capillary, bulb, thermal system legs, bridge, and yoke. Also check for excessive corrosion on the valve body.
3. Perform the instructions in **Testing the Thermal System**. Less than full valve travel may indicate a leak in the bellows, capillary, or bulb, or other problems. This may result in excessive temperature in the process.
4. Test the temperature adjusting nut assembly for freedom of movement (see **Adjust Set Point** for instructions).
5. Remove bulb from the process fluid and check for excessive corrosion, or erosion that may weaken the bulb and/or cause thermal system failure.

TROUBLESHOOTING

WARNING: Failure of the thermal system will result in a constant rise in temperature (or constant high temperature) of the fluid which you are trying to control.

• Erratic temperature control (valve cycles too hot/too cold)

1. Valve sized incorrectly. Verify valve selection.
2. Regulator is controlling at incorrect set point. Refer to **Adjust Set Point**.
3. Bulb is poorly positioned and/or oriented, and will not control the actual temperature of the heating/cooling medium. Refer to **Install Bulb**.
4. Incorrect type of bulb is being used. See Table on page 11.
5. The valve stem is sticking. Lubricate the stem.
6. The valve stem is bent. Refer to **Maintenance** for disassembly instructions and replace.
7. Packing gland assembly too tight. Loosen packing gland nut.
8. Faulty or incorrect steam traps. Replace with correct steam trap.
9. Very wet steam. Install a high pressure steam trap just ahead of the valve to drain off condensate that collects in the steam line.

• Regulator does not shut off

1. Pressure differential is greater than allowable pressure drop. Refer to Tables on pages 3 and 4.
2. Plug and/or seat is worn. Replace plug, seat or valve body (refer to **Maintenance**).
3. Foreign material between the plug and the valve plug seat. Refer to **To replace the plug or seat ring** for disassembly. Clean.
4. Bulb is poorly positioned and/or oriented, and will not control the actual temperature of the heating/cooling medium. Refer to **Install Bulb**.
5. Incorrect type of bulb is being used. See Table on page 11.
6. Valve sized incorrectly, causing wire drawing and leakage. Refer to **Water Capacities** and **Steam Capacities** tables.
7. Packing gland assembly is too tight, locking valve stem. Loosen packing gland assembly and lubricate if desired.
8. Bent valve stem; need to replace. Refer to **Maintenance** for disassembly instructions.
9. Thermal system failure. Refer to **Testing the Thermal System**.
10. Temperature adjusting nut assembly raised too high. Refer to **Adjust Set Point**.

(continued on page 16)

WARNING:
Failure of the #11's thermal system will cause a heating valve to full open and a cooling valve to full close. If either of these valve states results in an unsafe process condition, a high-limit shutdown device, such as a Powers Aqua Sentry, should be used.

DIMENSIONS

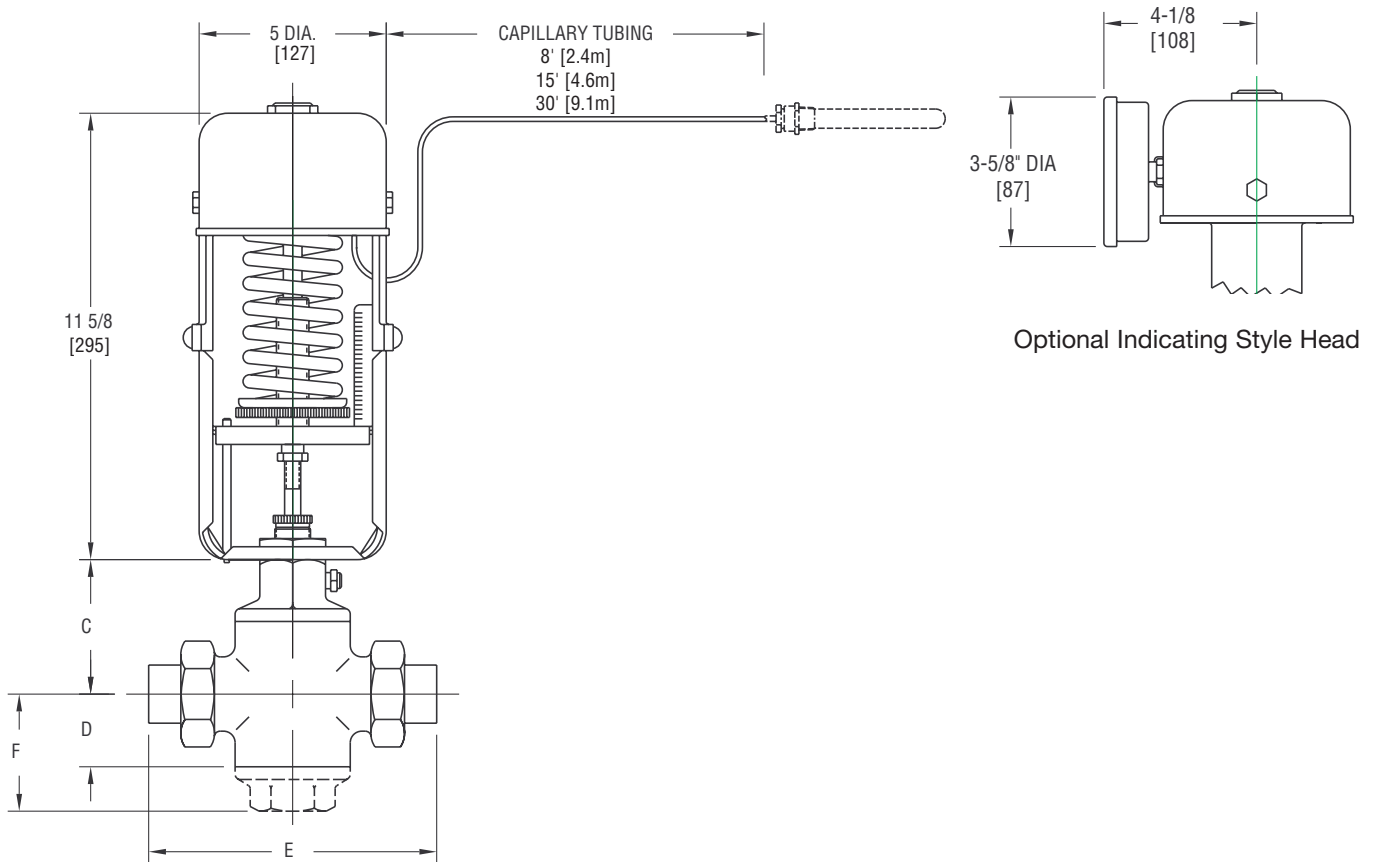

VALVE DIMENSIONS

Valve Size	C (in)	D (in) *	E	F (in) **	Travel (in)	Actual Weight (Lbs.)	
						Non Indic.	Indicating
1/2"A	2 1/2	1 1/4	5 5/8	-	1/4	19	21
1/2"B	2 1/2	1 1/4	5 5/8	-	1/4	19	21
1/2"C	2 1/2	1 1/4	5 5/8	-	1/4	19	21
1/2"D	2 1/2	1 1/4	5 5/8	-	1/4	19	21
1/2"	2 1/2	1 1/4	5 5/8	1 3/4	1/8	19	21
3/4"	2 5/8	1 3/8	6	2	3/16	20	22
1"	2 3/4	1 1/2	6 3/4	2 1/4	1/4	22	24

Valve Size	C (mm)	D (mm) *	E (mm)	F (mm) **	Travel (mm)	Actual Mass (Kg)	
						Non Indic.	Indicating
1/2"A	64	32	143	-	6	8.6	9.5
1/2"B	64	32	143	-	6	8.6	9.5
1/2"C	64	32	143	-	6	8.6	9.5
1/2"D	64	32	143	-	6	8.6	9.5
1/2"	64	32	143	44	3	8.6	9.5
3/4"	67	35	152	51	5	9.1	10
1"	70	38	171	57	6	10	10.9

* DA

** RA

BULB DIMENSIONS

Bulb Style	Size	Material	A (in)	B (in)	Max. Pressure - PSI	
					Shock	Non-Shock
D Fixed Union (& V-Vertical Fixed Union)	1 x 9	Copper	15/16	8	175	250
		347 Stainless	15/16	8 1/16	500	725
	1 x 20	Copper	15/16	19 7/8	175	250
		347 Stainless	15/16	19 13/16	500	725
J Plain Bulb*	1 x 9	347 Stainless	15/16	8 3/4	-	-
		Teflon Coated	15/16	8 3/4	-	-
	1 x 20	347 Stainless	15/16	20 1/2	-	-
		Teflon Coated	15/16	20 1/2	-	-
JD Adjustable	1 x 9	347 Stainless	15/16	8 3/4	500	725
	1 x 20	347 Stainless	15/16	20 1/2	500	725
G Finned Kit*	1 x 9	Copper	2	8 13/16	-	-
	1 x 20	Copper	2	20 15/16	-	-

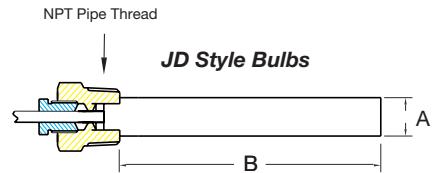
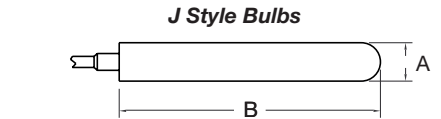
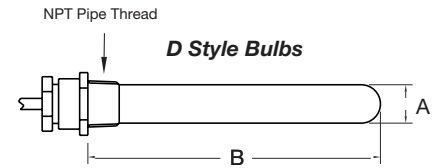

Bulb Style	Size	Material	A (mm)	B (mm)	Max. Pressure - kPa	
					Shock	Non-Shock
D Fixed Union (& V-Vertical Fixed Union)	1 x 9	Copper	24	203	4445	6350
		347 Stainless	24	205	12700	18415
	1 x 20	Copper	24	505	4445	6350
		347 Stainless	24	503	12700	18415
J Plain Bulb*	1 x 9	347 Stainless	24	222	-	-
		Teflon Coated	24	222	-	-
	1 x 20	347 Stainless	24	521	-	-
		Teflon Coated	24	521	-	-
JD Adjustable	1 x 9	347 Stainless	24	222	12700	18415
	1 x 20	347 Stainless	24	521	12700	18415
G Finned Kit*	1 x 9	Copper	51	224	-	-
	1 x 20	Copper	51	532	-	-

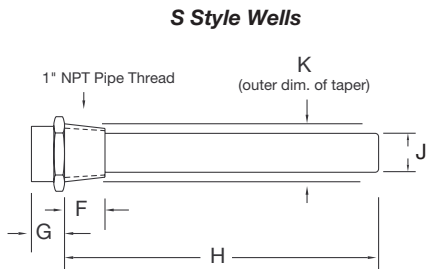
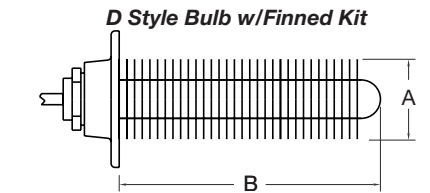

* J style bulbs and G Finned Kits are non-pressurized

WELL DIMENSIONS

Bulb Size	Well Kit #	Well Material	F (in)	G (in)	H (in)	J (in)	K (in)	Max. Well Pressure (PSI)	
								Shock	Non-Shock
1 x 9	709-193	Chrome Plated Copper	15/16	13/16	9 1/16	1	1.11	175	250
	808-478	316L Stainless Steel	1 1/16	13/16	8 11/16	1 1/64	1.11	450	675
	808-476	Carbon Steel	1	1 13/16	7 11/16	1 1/8	1.125	1000	1500
1 x 20	709-075	Chrome Plated Copper	15/16	13/16	21	1	1.11	175	250
	808-475	316L Stainless Steel	1 1/16	13/16	20 3/8	1 1/64	1.11	450	675

Bulb Size	Well Kit #	Well Material	F (mm)	G (mm)	H (mm)	J (mm)	K (mm)	Max. Well Pressure (kPa)	
								Shock	Non-Shock
1 x 9	709-193	Chrome Plated Copper	24	21	230	25	28	1207	1724
	808-478	316L Stainless Steel	27	21	221	26	28	3103	4654
	808-476	Carbon Steel	25	46	195	29	29	6895	10342
1 x 20	709-075	Chrome Plated Copper	24	21	533	25	28	1207	1724
	808-475	316L Stainless Steel	27	21	518	26	28	3103	4654

PARTS LIST

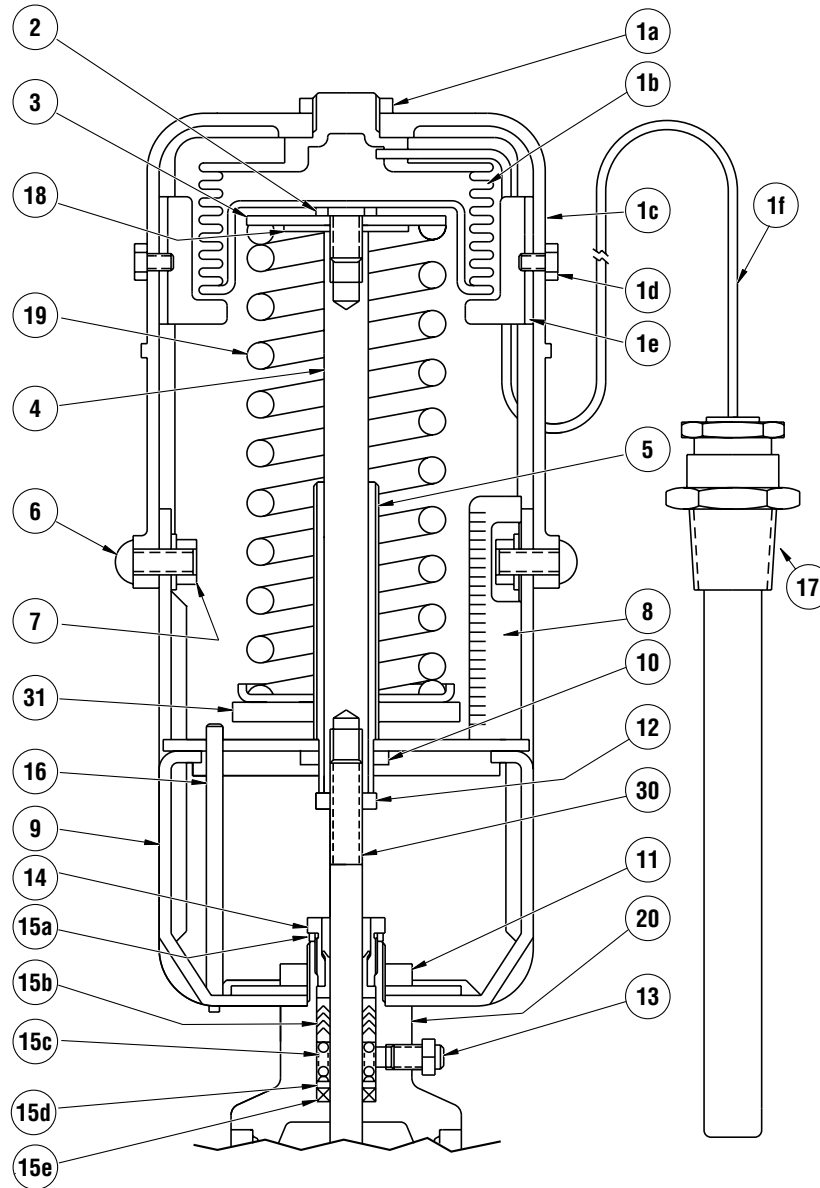

1/2A, 1/2B, 1/2C, 1/2D REDUCED PORT
1/2", 3/4", 1" STAINLESS STEEL TRIM*
DIRECT ACTING

1/2A, 1/2B, 1/2C, 1/2D REDUCED PORT
1/2", 3/4", 1" STAINLESS STEEL TRIM*
REVERSE ACTING

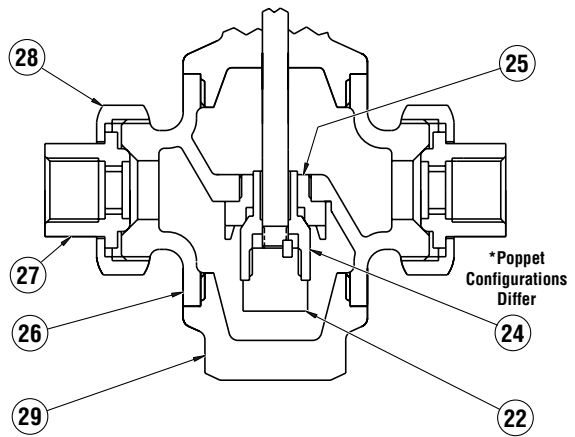
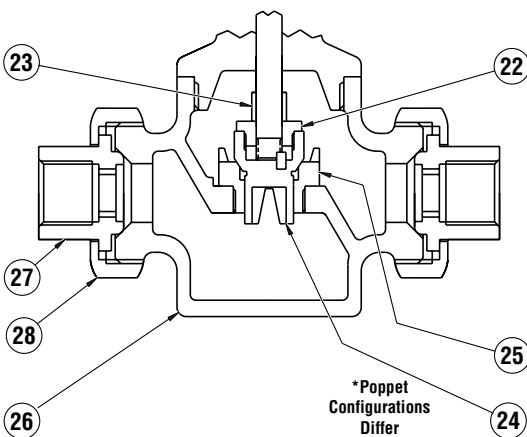

Item	Description	DIRECT ACTING							REVERSE ACTING							Qty	Material
		1/2A	1/2B	1/2C	1/2D	1/2"	3/4"	1"	1/2A	1/2B	1/2C	1/2D	1/2"	3/4"	1"		
1	Thermal System	Refer to Order Code							Refer to Order Code							1	-
1a	Locknut	Not sold as separate part - refer to Thermal System							Not sold as separate part - refer to Thermal System							1	-
1b	Thermal Motor/Bellows	"							"							2	-
1c	Housing	"							"							1	-
1d	Screw	"							"							2	-
1e	Bellows Stop	"							"							2	-
1f	Bulb/Capillary Assembly	"							"							1	-
2	Piston Plate Retaining Screw	590 816							590 816							1	SS
3	Piston Plate Washer	590 815							590 815							1	Zn plated Stl
4	Stem Extension	590808B							590808B							1	Brass
5**	Spring Adjustment Screw	590 807							590 807							1	Brass
6	Screw	030546J							030546J							2	Zn plated Stl
7	Hex Nut 5/16 x 18	041225K							041225K							2	Cd plated Stl
8	Temp. Adj. Setting Scale	590 813							590 813							1	Aluminum
**	Lower Housing Assembly	590 859							590 859							1	-
9**	Yoke and Bridge Assembly	Not sold as separate part							Not sold as separate part							1	-
10**	Nut, hex	041167J							041167J							1	Zn plated Stl
11	Nut, hex	041 125							041 125							1	Brass
12	Locknut	628 008							628 008							1	Brass
13	Pipe Plug	403 007							403 007							1	Brass
13	Stem Lubricator Kit	590184A							590184A							1	-
14	Packing Gland Assembly	590 763							590 763							1	Brass
15	Packing Kits	See Accessories List on p.14							See Accessories List on p.14							1	-
15a	Packing Spacer	"							"							1	-
15b	Packing Set	"							"							1	-
15c	Packing Spring	"							"							1	-
15d	Packing Washer	"							"							1	-
15e	Packing Ring	"							"							1	-
16	Temp. Adj. Rod	590 820							590 820							1	Cd plated Stl
17	1" Tank Fitting	705 005							705 005							1	Brass
18	Spring Guide Washer	590 814			590 814	590 814	595 503	590503				590 814	590 814	595 503	1	Zn plated Stl	
19	Spring	-	-	-	-	590 821	590 821	-	-	-	-	590 821	590 821	-	1	Zn plated Stl	
19	Spring, inner	595 501			-	-	595 501	595 501				-	-	595 501	1	Zn plated Stl	
19	Spring, outer	595 502			-	-	595 502	595 502				-	-	595 502	1	Zn plated Stl	
20	Bonnet Assembly	590 131			590 131	590 134	594 499	590 131				590 131	590 134	594 499	1	Brass	
22	Stem Retainer	590 604			590 604			590 605				590 606	590607A	590607B	1	SS	
23	Spacer Bushing/Stop Sleeve	609019C				609019C	609 019	609019A	-	-	-	-	-	-	-	1	Brass
24	Valve Plug/Poppet	590 566	590 567	590 568	590 569	590 650	590 664	590 665	590 575	590 576	590 577	590 578	590 651	590 666	590 667	1	SS
25	Seat Ring	590 608			590 608			590 608				590 608	590 610	590 612	1	SS	
26	Body Assembly	590 487			590 487	590 488	594 505	590 584				590 584	590 585	594 506	1	Bronze	
27	Union Tail Piece	601 005			601 005	602 005	609 003	601 005				601 005	602 005	609 003	1	Brass	
28	Union Nut	601 004			601 004	602 004	609 004	601 004				601 004	602 004	609 004	1	Brass	
29	Valve Cap	-	-	-	-	-	-	-	656 527				601 007	602 007	604 002	1	Brass
30	Stem Assembly	594814D							594814H							1	-
31**	Temp. Adj. Nut Assembly	590 829							590 829							1	-

ACCESSORIES

Packing kits can be ordered to replace parts in the packing assembly (See pages 10 & 11).

Kit #	Material	Valve Size	Stem Size	Usage	Parts	Lubricant
591 927	Teflon V-ring	1/2" - 2"	1/4"	Effective from 200°F-400°F Steam: 50 - 200 psi	15A, 15B 15C, 15D 15E	None
594 220	EP V-ring	1/2" - 2"	1/4"	Effective from 0°F-300°F Steam: 50 PSI maximum Water: up to maximum PSI valve rating	15A, 15B 15C, 15D 15E	Silicone required for installation (optional for service)
594 289	TFE Split Ring	1/2" - 2"	1/4"	For replacement only Effective from 40°F-366°F	15B, 15D	Silicone Part #087 126

Kit #	Bulb Dims.	Width (in)	Length (in)	Description
701 549	1 x 9	2	8 13/16	G Style Finned Kit (Copper)
701 550	1 x 20	2	20 15/16	G Style Finned Kit (Copper)

Finned Bulb Kits may be added to style "D" Bulb as noted.

TEMPERATURE RANGES/BULB SIZES

For ordering thermal systems, refer to order code, the Powers #11 Product Specification Brochure, or call Powers.

Bulb Size	Bulb Temp. Range		Order Code
	Single Seat 1/2" to 1"		
	Heating DA	Cooling RA	
1" x 20"	10-70°F (-12-21°C)	0-60°F (-18-16°C)	01
	55-115°F (13-46°C)	45-105°F (7-41°C)	02
	85-145°F (29-63°C)	70-130°F (21-54°C)	03
	-	90-150°F (32-66°C)	04
1" x 9"	110-170°F (43-77°C)	110-150°F (43-66°C)	05
	130-190°F (54-88°C)	-	06
	140-200°F (60-93°C)	120-180°F (49-82°C)	07
	170-230°F (77-110°C)	150-210°F (66-99°C)	08
	200-250°F (93-121°C)	185-245°F (85-118°C)	09
	230-290°F (110-143°C)	220-280°F (104-138°C)	10
	270-330°F (132-166°C)	255-315°F (124-157°C)	11

ORDER CODE

	Valve Assembly	Thermal System Assembly
<p>595-</p> <p>Valve Type Single Seat Stainless Steel</p> <p>Valve Sizes 1/2A 1/2B 1/2C 1/2D 1/2" 3/4" 1"</p> <p>Applications Heating Cooling</p> <p>Bulb/Capillary Material & Length Copper 8' Copper 15' Copper 30' Stainless Steel 8' Stainless Steel 15' Stainless Steel 30' Teflon over Copper 15' (J Bulb Only) Teflon over SS 15' (J Bulb Only)</p> <p>Bulb Size Fixed Union (N/A Teflon) No Pipe Fittings (N/A Copper) Adj. Union (N/A Teflon) Fixed Union (D Type) Vertical</p> <p>Head Assembly Non-Indicating Indicating</p> <p>Range/Bulb Size See chart on page 14 Select Range with Set Point in UPPER THIRD for best performance.</p>	<p>ST</p> <p>A50 B50 C50 D50 050 075 100</p> <p>H C</p> <p>C08 C15 C30 S08 S15 S30 T15 O15</p> <p>D J A V</p> <p>N I</p> <p>##</p>	<div style="display: flex; justify-content: space-between;"> <div style="width: 10%;"></div> <div style="width: 10%;"></div> <div style="width: 10%;"></div> <div style="width: 10%;"></div> <div style="width: 10%;"></div> <div style="width: 10%;"></div> <div style="width: 10%;"></div> <div style="width: 10%;"></div> </div>

For additional information on your application or equipment, please contact a Powers application engineer.

Continued from page 9

• **Valve chatters**

1. Regulator installed with the flow of the control medium in reverse of arrow direction on valve body.
2. Pressure differential too high, refer to Tables on pages 3 and 4 for correct pressure differential range.
3. Trapped condensate in line. Install a steam trap just ahead of the regulator to drain off condensate that collects in the steam line.

• **Constant high (too hot) or rising temperature of the process fluid**

1. **DA (Heating Valve):** A constantly high or rising temperature may indicate the thermal system is leaking charge and/or the valve has failed in a partially or fully open position. This would allow a constant flow of heating medium, which would overheat the fluid which you are trying to control.
2. **RA (Cooling Valve):** A constantly high or rising temperature may indicate the thermal system is leaking charge, and/or the valve has failed in a partially or fully closed position. This would slow or stop the flow of cooling medium which would overheat the fluid which you are trying to control.

CALIFORNIA PROPOSITION 65 WARNING

WARNING: This product contains chemicals known to the State of California to cause cancer and birth defects or other reproductive harm. (Installer: California law requires that this warning be given to the consumer.)

For more information: www.wattsind.com/prop65

POWERS

A WATTS INDUSTRIES CO.

© October 2002 Powers, a Watts Industries Co.

USA office: Phone: 800.669.5430 • Fax: 847.824.0627 • www.powerscontrols.com

Canadian office: Phone: 888.208.8927 • Fax: 888.882.1979