

#### DESCRIPTION

With the Powers Hydropanel II Modular Shrouding System you can specify standardized shrouding panels to cover all shower room piping, without the expense of customized components. By using the Powers specification charts, you coordinate different sizes of the five panel types, based on

the dimensions of your shower room. The modular components promote easy installation and fast delivery. Hydropanel II Modular Shrouding is stainless steel and utilizes vandal resistant fasteners with standardized heads.

#### GETTING READY

To install Hydropanel II Modular Shrouding, follow the room layout drawing from Form #PS450SH. The product specification diagram not only describes the positions of the different types and sizes of shrouding, but also provides the following information:

- Room dimensions and showerhead height.
- The number of shower units in the plan.
- The beginning, end and changes in direction of the supply piping.
- The walls on which to mount the corner shrouding.

On each shrouding component is a letter-number code that represents panel type and length (as listed below). Shrouding components install in the following general order, in the following situations:

- 1. Horizontal Adapters (A16, A24, A48)**
  - a. Piping bends/ends-of-run.
  - b. Hydropanel II units.
- 2. Corner Adapters - going into the corner (C10)**

Fit the Corner Adapter onto the appropriate wall.
- 3. Extensions (E6, E24)**
  - a. Into the cutout on top of the Horizontal Adapters.
  - b. Vertically onto the top of a Hydropanel II unit.
  - c. Special cases: on an open end of an Adapter to extend its reach.

#### 4. Overlays (O8, O13, O18, O23, O28)

- a. Between two Horizontal Adapters.
- b. Between a Corner Adapter and Horizontal Adapter on the same wall.
- c. Between a Corner Adapter and Horizontal Adapter on adjacent walls (90° angle).
- d. Between the ceiling and an Extension.
- e. Special cases: between an Extension and an Adapter.

#### 5. End Caps

Fit End Caps onto the open ends of Horizontal Adapters or atop an open Hydropanel II unit.

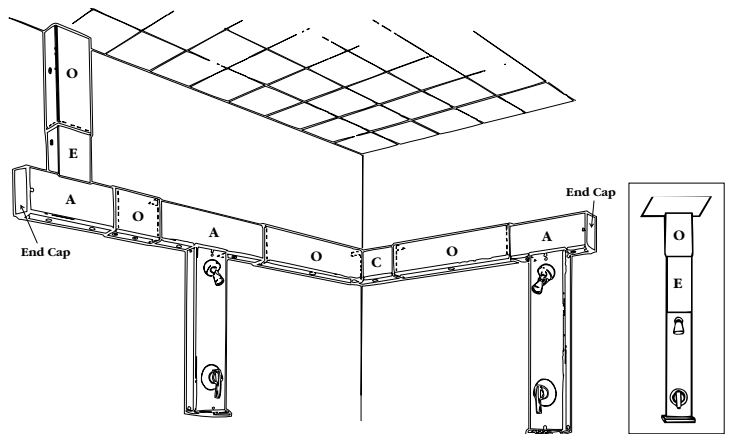

#### GUIDELINES

1. The distance between the centerlines of two vertical sections (vertical piping run or Hydropanel II unit) should be at least 18" [460 mm]. Recommended standard distance is 36" [915 mm].
2. The distance between the centerline of any vertical section (vertical piping run or Hydropanel II unit) and a wall should be at least 20" [510 mm].
3. The distance between the top of a Hydropanel II unit and the ceiling should be at least 9-1/2" [940 mm].
4. 16" [405 mm] Horizontal Adapters are used at the end of a piping run.
5. Each Corner Adapter, 13", 16", 18", 23", or 28" Overlay, or Extension Kit includes a stainless steel panel, and (2) mounting brackets with (2) screws. Each Horizontal Adapter or 8" Overlay Kit includes a stainless steel panel and (4) mounting brackets with (4) screws (wall mounting screws not provided).
6. The 16" Horizontal Adapter Kit includes an End Cap Kit. The End Cap Kit comes complete with (1) chrome plated end cap and (3) mounting screws.
7. Position the brackets on the wall according to the dimensions of the individual piece of shrouding (refer to pages 3 and 4 for drawings). You can also hold the piece of shrouding to the wall as a template to determine bracket position.
8. All brackets mount with the 1/4" hole to the wall, facing in (refer to Figure 1).
9. The 3/4" wide oval mounting holes on the shrouding allow up to 1/2" error in shroud/bracket mounting.

Figure 1. Mounting Brackets and Shrouding

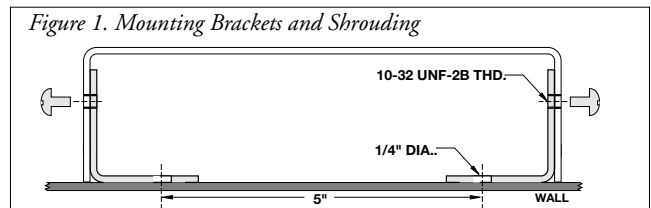

**INSTALLATION**

Use your Specification diagram from Form #PS450SH and Figure 4 as keys to shrouding component positioning.

**1. Mount all Hydropanel II shower units and End Caps**

For complete shower installation instructions, refer to the Technical Instructions for each Hydropanel II shower unit (Form #TI450-410, -420, -900, or -M)

**2. Draw level lines for the horizontal shrouding.**

(Figure 2) Brackets for the horizontal shrouding will mount on "upper" and "lower" level lines. Draw a horizontal line 8-9/16" above showerhead height centerline. Then draw a horizontal line 5" below this upper level line. Extend both lines around the shower room for all horizontal shrouding.

**3. Draw plumb lines for the vertical shrouding.**

(Figure 3) Brackets for the vertical shrouding will mount along "left" and "right" plumb lines. Strike a mid-line on the wall at the shower unit/vertical section centerline (halfway between the hot and cold supply water pipes). Draw one vertical line 2-1/2" to the left and one 2-1/2" to the right of the mid-line. Extend both plumb lines for all vertical piping.

**4. Mount Horizontal Adapters (A).**

Horizontal Adapters fit over piping bends and Hydropanel II units, and use two upper and two lower mounting brackets. The horizontal space between the two sets of mounting brackets depends on component length. Refer to the dimensional drawing, or hold Adapter in position to mark bracket positions. Attach brackets to the wall, mount Adapter and secure to the brackets with 10-32 screws (included).

**5. Mount Corner Adapters (C).**

Consult the Specification diagram from Form #PS450SH to determine on which adjoining wall to mount the Corner Adapter(s). Proper installation of all shrouding pieces depends upon correct positioning of the Corner Adapters. Brackets for corner shrouding mount 5" out from the room corner (see dimensional drawing). Attach brackets to the wall, mount Adapter and secure to the brackets with 10-32 screws (included).

**6. Mount Vertical Extensions (E).**

(Figure 4, next page) Vertical Extensions fit into the cut-out on a Horizontal Adapter or onto the top of a Hydropanel II unit. Use the Extension as a template, or determine the bracket position (one left and one right) with the dimensional drawing. Attach brackets to the wall, then mount Adapter and secure to the brackets with 10-32 screws (included).

**7. Mount Horizontal Extensions (not shown)**

Before mounting a Horizontal Extension to extend the reach of an Adapter, fit and secure an End Cap into the appropriate Adapter end. The End Cap functions as a gasket between these two pieces that cannot overlap. Then use the Horizontal Extension as a template to mark the positions of the upper and lower brackets (1 each). Attach brackets to the wall, mount Adapter and secure to the brackets with 10-32 screws (included).

**8. Mount all Overlay Shrouding (O).**

The Hydropanel II Modular Shrouding system specifies Overlay shrouding that overlaps Adapters and Extension about 1" on each side (but can be more). To determine the position of the mounting brackets on the wall, either a) measure the distance between the pieces it overlaps (Extensions, ceiling, wall, Adapters, etc.) and divide this distance in half; or b) place the Overlay in position and mark the locations of the bracket mounting holes. Attach brackets to the wall, mount Adapter and secure to the brackets with 10-32 screws (included).

**9. Mount end-of-run End Caps.**

Each 16" Horizontal Adapter Kit includes an end cap. Position End Cap on the open end of the Adapter and attach with the 3 screws provided (no drilling or mounting brackets necessary).

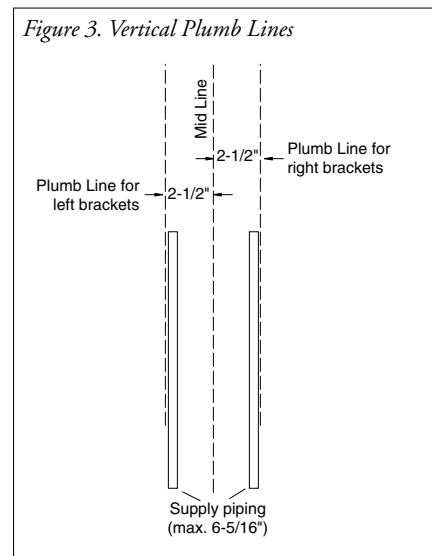
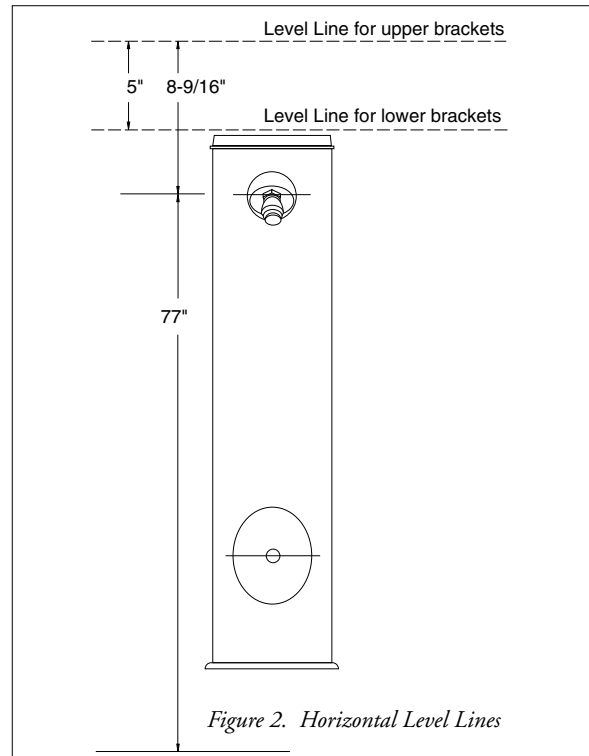

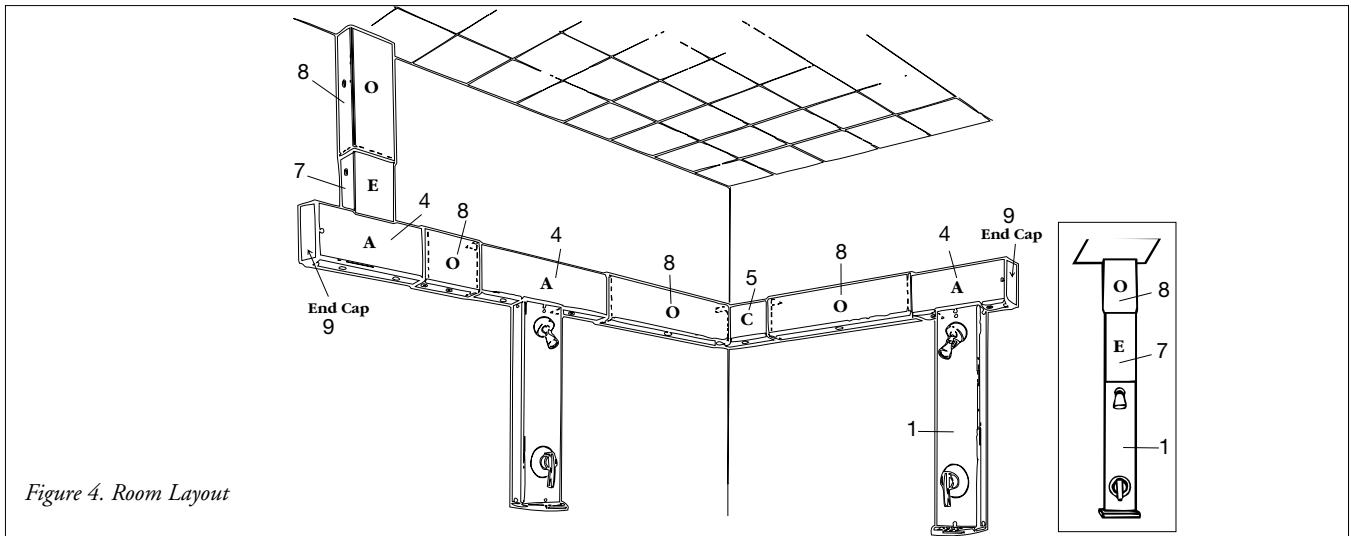
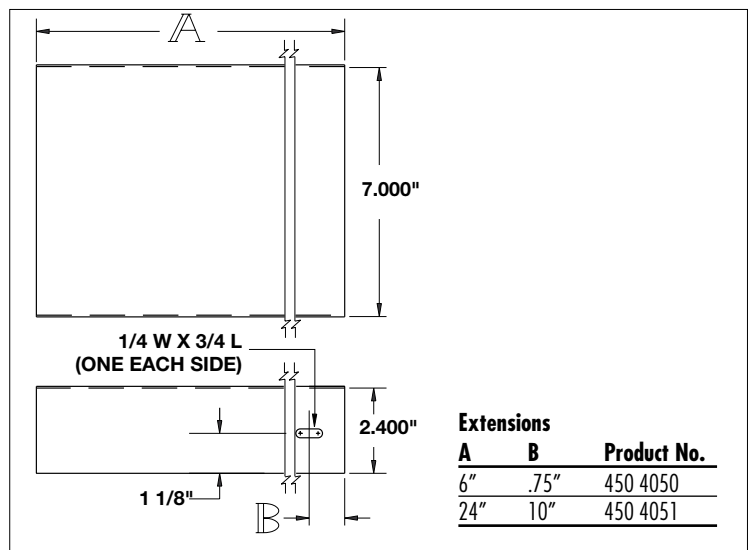
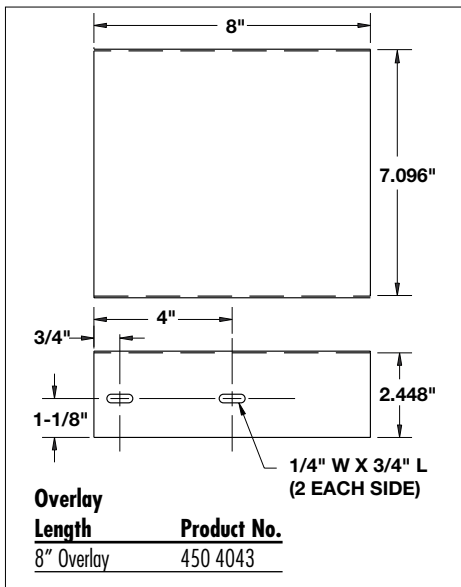
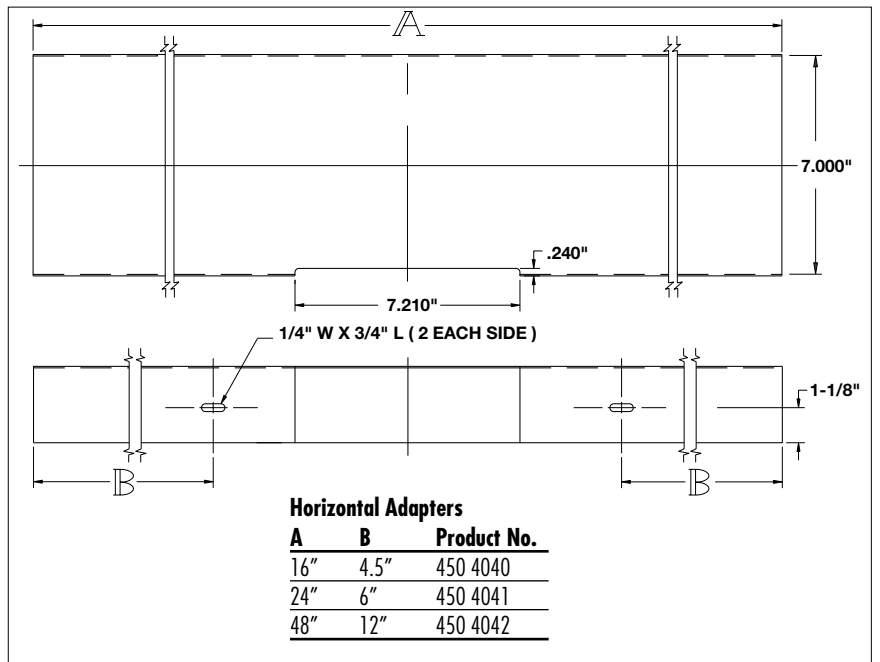
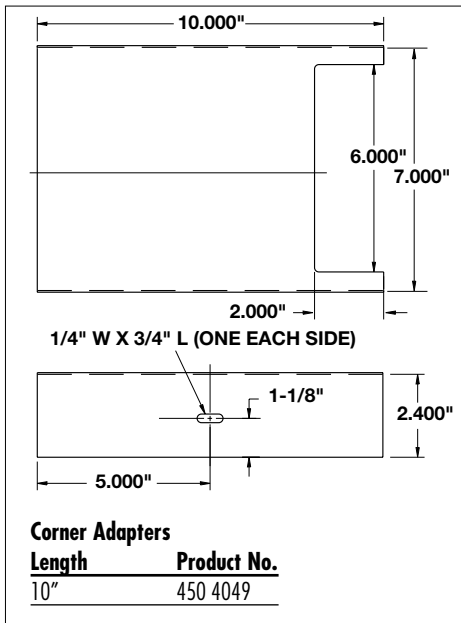
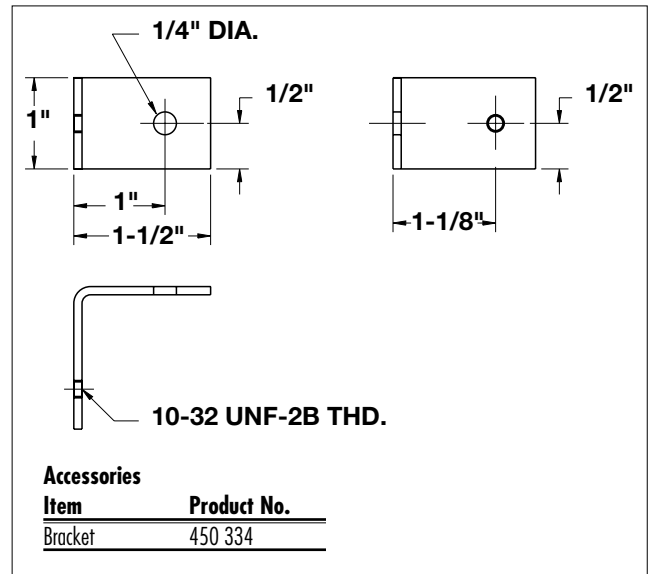
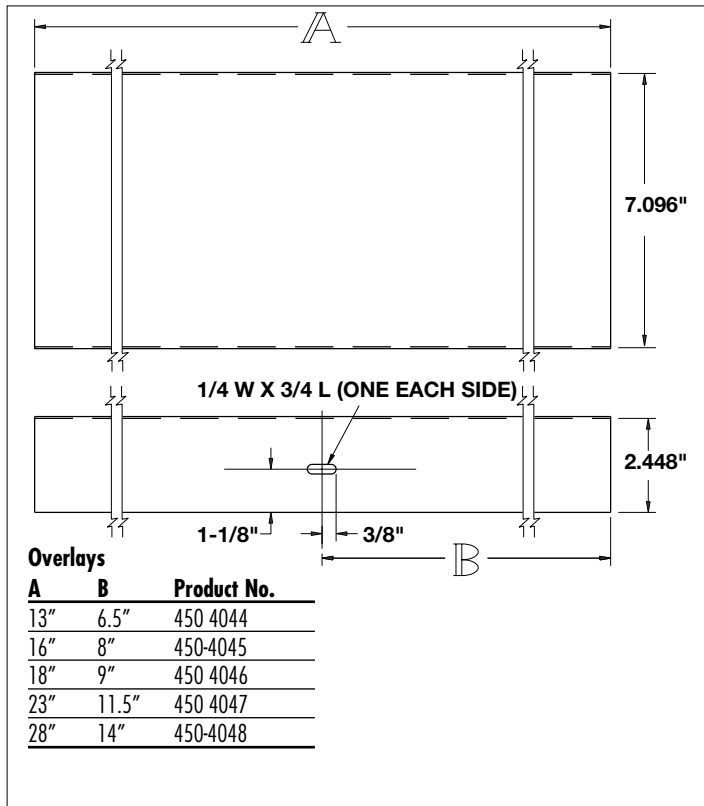

Figure 4. Room Layout

**DIMENSIONS**





**CALIFORNIA PROPOSITION 65 WARNING**

**WARNING:** This product contains chemicals known to the State of California to cause cancer and birth defects or other reproductive harm. (California law requires this warning to be given to customers in the State of California.) For more information: [www.wattsind.com/prop65](http://www.wattsind.com/prop65)

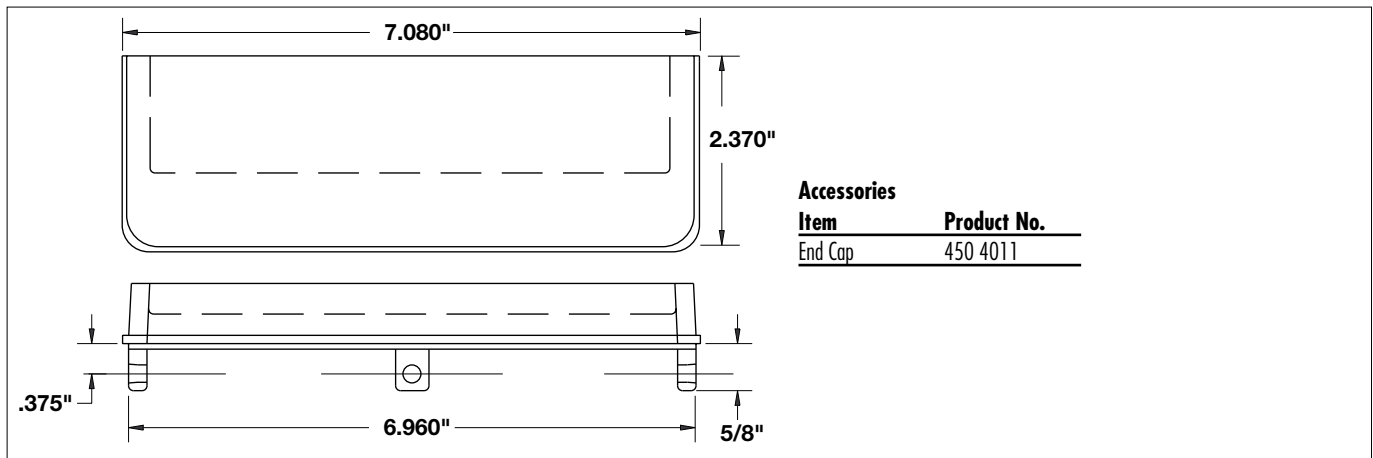

**ORDERING**

Qty	Description	Size	(Metric)	Order #
	Horizontal Adapter Kit	16"	405mm	450 4040
	Horizontal Adapter Kit	24"	610mm	450 4041
	Horizontal Adapter Kit	48"	1220mm	450 4042
	Overlay Shroud Kit	8"	205mm	450 4043
	Overlay Shroud Kit	13"	330mm	450 4044
	Overlay Shroud Kit	16"	405mm	450 4045
	Overlay Shroud Kit	18"	455mm	450 4046
	Overlay Shroud Kit	23"	585mm	450 4047
	Overlay Shroud Kit	28"	710mm	450 4048
	Corner Adapter Kit	10"	255mm	450 4049

Qty	Description	Size	(Metric)	Order #
	Extension Shroud Kit	6"	150mm	450 4050
	Extension Shroud Kit	24"	610mm	450 4051
	End Cap Kit			450 4011
	Bracket Kit			450 334

Each Hydropanel II Modular Shrouding Corner Adapter, 13", 16", 18", 23", or 28" Overlay, or Extension Kit comes complete with stainless steel panel, and (2) mounting brackets with (2) screws. Each Horizontal Adapter or 8" Overlay Kit comes complete with stainless steel panel and (4) mounting brackets with (4) screws. The 16" Horizontal Adapter Kit also includes an End Cap kit. The End Cap Kit comes complete with (1) chrome plated end cap and (3) mounting screws.



© 2003 Powers, a Watts Industries Co.  
 USA Phone: 1.800.669.5430 • Fax 1.877.459.3440  
 Canada Phone: 1.888.208.8927 • Fax 1.888.882.1979  
[www.powerscontrols.com](http://www.powerscontrols.com)