

DESCRIPTION



Figure 1. ESP Hydropanel II Series 450-5000 Infrared System

The ESP (Electronic Sensor Plumbing) Hydropanel II Infrared Shower System combines modular shrouding with the convenience of electronic water control. The Hydropanel II shrouding provides a concealed shower system where in-wall piping does not exist or may not be practical. The ESP Infrared Shower System relies on infrared technology to sense the presence of a user and deliver tempered water to the shower with completely hands free operation. The shower automatically turns on when the bather enters the infrared field of the sensor, and continues to operate as long as the bather stands in front of the sensor, up to the field adjustable run-time.

The Powers Series 450 ESP Infrared shower systems come complete with stainless steel Hydropanel II shrouding, ESP Infrared Shower System, showerhead, piping, soapdish and mounting hardware. The ESP Infrared Sensor Assembly consists of infrared

sensor, modular junction box, wiring, solenoid valve and 24V AC transformer.

The following instructions serve as a guide for installation of the Powers ESP Hydropanel II Infrared Sensor shower systems. Powers recommends good safety practices and care when installing electrical equipment. Please follow the procedures as outlined. For additional assistance, please call the Powers Applications Engineering Department at 1.847.824.9723.

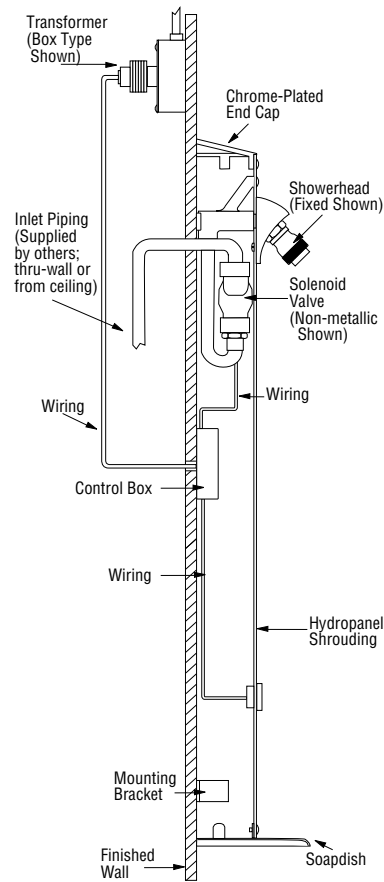

Figure 2.
Typical Shower Installation

INSTALLATION

Precautions Before Installation:

- Use a 24V AC step-down transformer for single and group shower applications.
- Do not supply power to, or plug in, the transformer until all other wiring is complete. To prevent permanent damage to the transformer, do not allow power transformer wires to touch during wiring.
- Before connecting the solenoid valve, flush Hydropanel supply lines to ensure supply water will be free of grit, sand, etc. The solenoid valve requires water free of all foreign matter to operate properly.
- To inhibit corrosion, a waterproof, multi-purpose, aerosol grease may be sprayed onto all electrical contacts.
- Follow the national/local codes and regulations for all electrical wiring and plumbing.
- Use stainless steel screws for all component installations.

Tools Required:

- Slotted and Phillips screwdrivers.
- Drill with 5/8" bit.
- Pipewrenches.
- Pipe dope/sealing compound.
- Allen Wrench(s) (included with shrouding).

The ESP Hydropanel II Shower System includes a solenoid valve (brass) which receives tempered water through pre-installed piping. A Powers master mixing valve such as the 430 Thermostatic mixing valve, or Hi-Lo cabinet supply fixture, can be used to supply safe comfortable water to the ESP Hydropanel shower system.

INSTALLATION, CONTINUED

Figure 3. Front and side views - Dimensions of the ESP Hydropanel II Infrared Shower

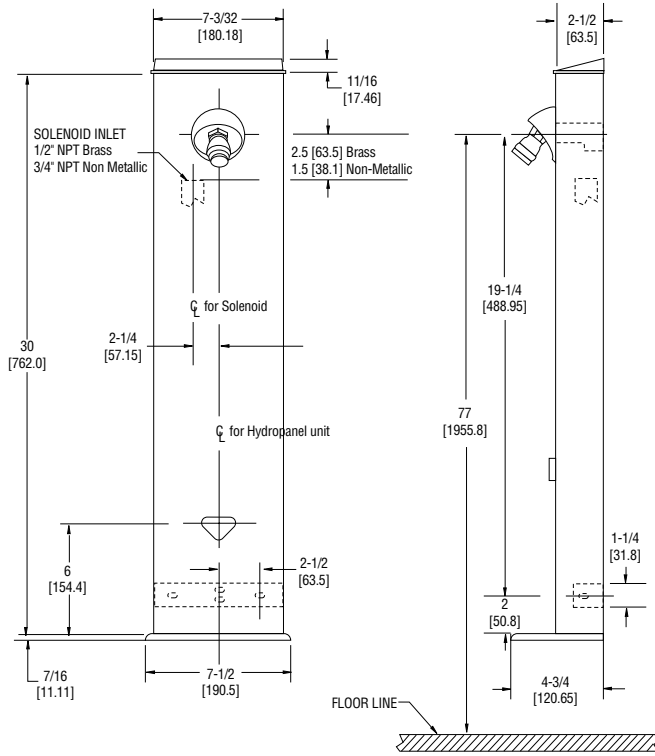

For Suggested Showerhead Heights see Installation: Positioning the ESP Hydropanel II unit

Position the ESP Hydropanel II Unit

Determine the horizontal position of the unit according to shower room layout, and mark the centerline (Figure 3). For multiple shower applications, the recommended minimum distance between the centerline of two units is 36 inches.

Determine the floor-to-showerhead height for the unit. Recommended shower head heights are listed below:

- Men 77" [1955.8mm] - Youth 66" [1676.4 mm]
- Women 70" [1778mm] - Youth 60" [1524 mm]

Determine where the inlet piping will connect to the solenoid. For the non-metallic solenoid, this connection is typically 1-1/2" below showerhead height, and 2-1/4" left of centerline. For a brass solenoid, it is 2-1/2" below showerhead height, and 2-1/4" left of centerline (refer to Figure 3).

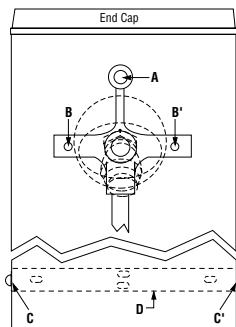

Figure 4.

Install the Solenoid and Piping

Assembly

The piping and Hydropanel II shrouding come pre-assembled (Figure 4). To detach, remove the screws at the showerhead (A) and bottom bracket (C and C'). Slide the piping out of shrouding; the showerhead remains part of the shroud.

WARNING: Before installing solenoid, flush the pipes to ensure supply water is free of grit and sand.

NOTE: A service stop can be installed directly upstream of the solenoid to facilitate maintenance and repair.

The brass solenoid has 1/2" NPT end connections.

Connect the supply line to the solenoid, using **only** thread sealant on male threads. **Do not use Teflon tape;** it will clog the solenoid valve. Connect the inlet piping so water flows in the direction of the arrow on the solenoid. To mount the upper bracket of the piping assembly, drill the holes at the same height as the top of the showerhead (B and B').

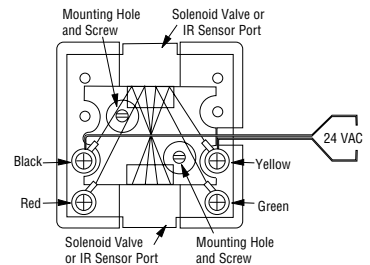

Figure 5.

Install Modular Junction Box

The Modular Junction Box (MJB) (Figure 5), with standard cables, can be positioned up to 2 feet from the infrared sensor and up to 2 feet from the solenoid valve. [Optional cable extensions can extend these distances to 1000 feet from the infrared sensor, and 300 feet from the solenoid valve.] Remove the cover. Use the box as a template to mark positions on the wall for two mounting screws. Drill holes and attach the box.

Connect one of the power supply wires (supplied with ESP kit) to the yellow terminal on the MJB, and the other wire to the black terminal. Tighten the screws for a secure connection. Replace the cover.

Install the Transformer

The plug-in and box mount transformers can be positioned in a chaseway, closet or ceiling. Each can power up to eight solenoids. For shower system maintenance, a remote shut-off switch can be installed.

WARNING: Do not supply power to or plug in the transformer until all wiring is complete.

• Plug-In Transformer

The plug-in transformer will connect to a 110V AC wall outlet. Connect the two power cord wires from the MJB to the screw terminals on the secondary side of the transformer (Figure 6). Tighten the screws. **NOTE:** The wires can be lengthened with 22 gauge bell wire.

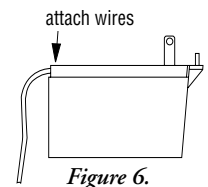

Figure 6.

• Box Mount Transformer

The box mount transformer will mount on a 110V AC supply electrical junction box. The "J" box should be inside the chase wall or above the ceiling. Connect the power supply wires from the MJB to the secondary side of the transformer (Figure 7). Tighten the screws.

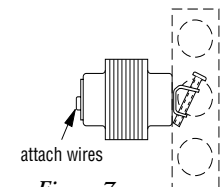
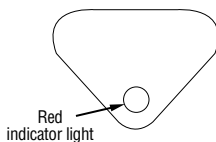

Figure 7.

INSTALLATION, CONTINUED

Figure 8.



ESP System Test

Before attaching shrouding, the ESP system should be tested. First, position and support the Hydropanel shrouding within all cable limits (on a chair, etc.). Do not turn on power or water supply yet.

Insert the plugs from the infrared sensor and the solenoid into the ports on the Modular Junction Box (Figure 5). **Either plug can go into either port on the MJB.**

Supply power to the transformer, and activate the infrared sensor by moving an object in front of it. The sensor activation light on the front of the sensor lens (Figure 8) will turn on to show proper sensor activation.

ESP Shower Sensitivity Adjustments

Each ESP Infrared Sensor has a potentiometer to adjust sensing distance from 2" to 48". The sensor is factory set at 18"— useful for most applications, depending on reflectivity of skin, room lighting, etc.

To adjust, locate the top dial on the back of the Infrared Sensor (Figure 9). With a small screwdriver, rotate the dial in small increments, clockwise for more distance, counter-clockwise for less. Turn dial carefully; over-adjusting can damage the potentiometer. After each adjustment, test the shower.

Figure 9.

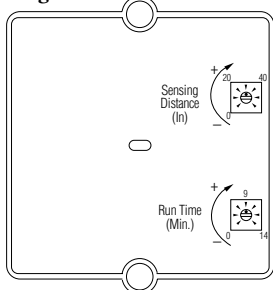

ESP Shower Time Adjustments

Although each ESP system will shut off the shower when a bather steps away from the sensor, it also has a potentiometer to set a maximum run-time, from 0 to 14 minutes. Factory setting is 14 minutes.

To adjust, locate the bottom dial on the back of the Infrared Sensor (Figure 9). With a small screwdriver, rotate the dial in small increments, clockwise for more time, counter-clockwise for less.

Turn dial carefully; over-adjusting can damage the potentiometer. After each adjustment, test and time the shower.

Reattach the Shrouding

The bottom bracket (Figure 4,D) will attach to the wall 19-1/4" below showerhead height (see Figure 3). Use the bracket as a template to mark positions for two mounting holes. Drill holes and attach the bracket.

The chrome plated end cap (Figure 4) on top of the shrouding has a section marked to be broken out for vertical and horizontal piping clearance. To remove the marked piece, hit it sharply with a hammer. **Do not remove** the entire end cap from the shrouding.

Connect the outlet side of the solenoid to the showerhead piping by sliding the showerhead nipple (with the shrouding unit) into the piping assembly.

Before reconnecting shrouding with screws, turn on water supply and activate the sensor to test the system. Water should flow

through showerhead. Deactivate sensor and check all connections for leaks.

Use screws to attach the shrouding to the piping bracket and to bottom mounting bracket (Figure 4, A and C).

OPERATION

- 1) When power is supplied to the ESP system, the sensor emits a continuous field of infrared beam.
- 2) A bather that steps into the range of this field activates the sensor. The sensor sends a signal through the modular junction box to the solenoid. The solenoid opens and allows tempered water to flow to the showerhead.
- 3) When the bather steps out of sensor range, a signal is sent to the solenoid to close and consequently stop the flow of water.
- 4) If the bather does not move away from the sensor, the shower will run until the pre-set maximum run time. After shut-off, the system is ready for reactivation.

SYSTEM MAINTENANCE

Routinely (twice a year) perform the following maintenance to ensure safe continuous operation of ESP Hydropanel units.

1. Inspect electrical connections for corrosion.
2. Check for any loose connections. Tighten if necessary.
3. Check solenoid valve for proper operation. Make sure it is free of dirt and lime build up.
4. Check that temperature of supply water is thermostatically controlled for safe comfortable bathing.

To clean the shower area without turning off the main water supply, either turn off the electricity to the ESP system (if possible), or simply apply a strip of dark opaque tape over the lens. Black electrical tape will work; it absorbs and does not reflect the infrared light. (The sensor shouldn't activate until the tape is removed.) **A mild soap may be used to clean the lens, but avoid abrasive cleaners; they may scratch the lens.**

MAINTENANCE AND TROUBLESHOOTING

The following are problems that may occur with the ESP Hydropanel II. Follow the listed steps toward a solution. For any further problems, call Powers Application Engineering Department at 1.847.824.9723.

1. If red LED on sensor lens (Figure 8) does not light to show that the sensor has detected a bather:
 - a. Check that an object was not in front of the sensor when unit powered up. The sensor will not operate until the object is removed and the sensor reactivated.
 - b. Check that transformer feed wires are securely attached to terminals at modular junction box and at transformer.
 - c. Check that power is being supplied to the transformer. Also, use a voltmeter to check that power is being supplied through the transformer. If power goes into the transformer but does not come out, replace the transformer.
 - d. If transformer functions properly and power is supplied, but LED still does not light, replace sensor assembly.
2. If no water flows from showerhead when bather tries to activate sensor:
 - a. Check that the red "sensor activation" LED lights. If not, see #1.
 - b. Check that the supply line is open and water is being supplied.

MAINTENANCE AND TROUBLESHOOTING , CONTINUED

- c. Check that solenoid wires are securely attached.
- d. The maximum run-time may have elapsed. The sensor will remain lit even though the solenoid has closed. For a longer shower-run time, reset the run-time potentiometer.
- 3. If water runs continuously, regardless of sensor activity:
 - a. **FIRST unplug solenoid from the modular junction box.**
 - b. If water continues to run...
 - Debris and/or lime build-up may be preventing solenoid from closing. Dismantle, clean and flush the solenoid valve
 - c. If water stops after disconnecting power...
 - The problem is electronic. Check that power wires are connected properly in the Modular Junction Box, and check all electrical connections.

PARTS LIST

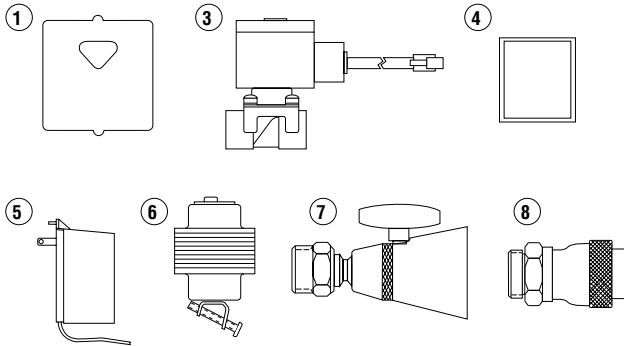

No.	Description	Part No.
1	Sensor Assembly for Infrared Shower	444 141
3	Solenoid Assembly (brass)	444 175
4	Installation Kit, Modular Junction Box	444 161
5	Plug In Transformer	444 118
6	Box Transformer	444 119
7	Swivel Showerhead	141 379
8	Fixed Showerhead	141 816
Not Shown	Maintenance/Repair Kit, Solenoid (brass)	444 183

CALIFORNIA PROPOSITION 65 WARNING

WARNING: This product contains chemicals known to the State of California to cause cancer and birth defects or other reproductive harm. (California law requires this warning to be given to customers in the State of California.) For more information: www.wattsind.com/prop65

POWERS™
A WATTS INDUSTRIES CO.

© 2003 Powers, a Watts Industries Co.
USA Phone: 1.800.669.5430 • Fax 1.877.459.3440
Canada Phone: 1.888.208.8927 • Fax 1.888.882.1979
www.powerscontrols.com