

DESCRIPTION

The Series 410 Hydroguard is a pressure compensating mixer which delivers a predetermined water temperature, compensating for pressure fluctuations in the hot or cold water supply.

The Series 410 Hydroguard features a poppet-type equalizing valve as part of a replaceable cartridge. The poppet-type construction offers a distinct advantage, it will not stick because of lime build-up or foreign particles in the supply. The adjustable maximum temperature stop prevents accidental scalding caused by overadjustment of the handle.

Many Series 410 valves and shower systems can be selected to meet the Americans with Disabilities Act (ADA) [see back page for details].

SPECIFICATIONS

Operating

Capacity: Shower and Tub
6 gpm at 45 psi differential [22.7 L/min at 310 kPa]
Maximum Static Pressure..... 125 psi [862 kPa]
Maximum Inlet Temperature..... 180°F [82°C]
Inlet and Outlet Sizes..... 1/2" NPT
Roughing-in Template..... All Models
Maximum Temperature Adjustment..... All Models
Complies to ASSE 1016 & CSA B125.....All Models

APPLICATION

The Series 410 Hydroguard is particularly recommended in showers and shower bath installations for motels, hotels, dormitories, and high rise apartment buildings.

OPERATION (SEE FIGURE 1)

Hot and cold water enter their respective ports and the pressures are equalized through the action of the balance poppet (1). The entire balancing poppet assembly is contained in a Celcon chamber (2). This chamber is replaceable as a complete cartridge. After the hot and cold pressures are equalized, they are mixed by the action of a mixing plate (3). As the temperature adjustment stem is rotated from shutoff to maximum hot water temperature, the mixing plate passes the required proportion of hot and cold water to produce the control point. With the adjustment stem in its full clockwise position, shutoff is obtained by closing both supplies.

The maximum temperature stop (4) allows the user to set the maximum discharge temperature. This mixer does not recognize supply water temperature changes, so any variation in the water temperature will affect the control point and the maximum temperature setting.



411/416

FIGURE 1 – OPERATION

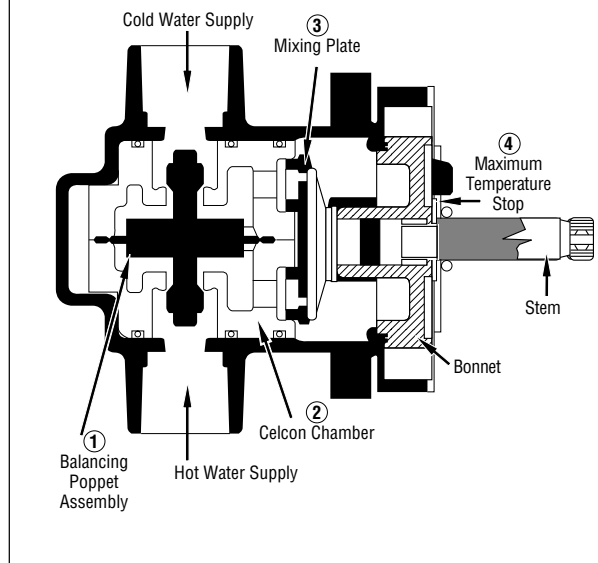

NOTE: Following any maintenance of unit, maximum temperature stop must be reset. See page 5 for instructions.

MAINTENANCE

Troubleshooting

What to look for:

- 1. The flow of water is less than desired.**
 - a. Valves upstream from supply not fully open.
 - b. Low supply pressures.
 - c. Accumulation of lime deposits in hot water pipes, restricting the flow of hot water.
 - d. Showerhead clogged.
 - e. Checkstops may not be fully open.
 - f. Low supply temperature (Hot Water).
- 2. Flow of water is completely shut off.**
 - a. Valves upstream from supply completely closed.
 - b. Failure of hot or cold water supply pressure. The Hydroguard is constructed to restrict the flow of water on hot or cold water supply failure.
 - c. Checkstops closed.
- 3. Flow is untempered hot or cold water.**
 - a. The water supplies are connected to the wrong ports.
 - b. Diaphragm is ruptured; replace with new cartridge.
 - c. Check for foreign material that may be clogging the cartridge.
- 4. Flow of water continues when Hydroguard is shut off.**
 - a. Worn shut-off discs. Replace worn disc.
 - b. Scratched mixing plate.
 - c. Erosion. Contact a Powers applications engineer to order replacement parts.
- 5. Maximum temperature is too low.**
 - a. Accumulation of lime deposits in hot water pipes, which restricts the flow of hot water.
 - b. The concealed maximum temperature limit stop is not at its maximum adjustment. See page 5 to set the maximum temperature limit stop.
 - c. Hot water temperature is too low.
- 6. Standard inlets are desired.**

See Figure 2 for instructions on standard inlets (with cold water entering the COLD port). With mixer in closed position, the notch in the top spline on the stem must FACE the outlet.
- 7. Reversed inlets are desired.**

Note: When using reversed inlets, the HOT and COLD inlets should be identified to avoid confusion during future maintenance.

FIGURE 2 – STANDARD INLETS

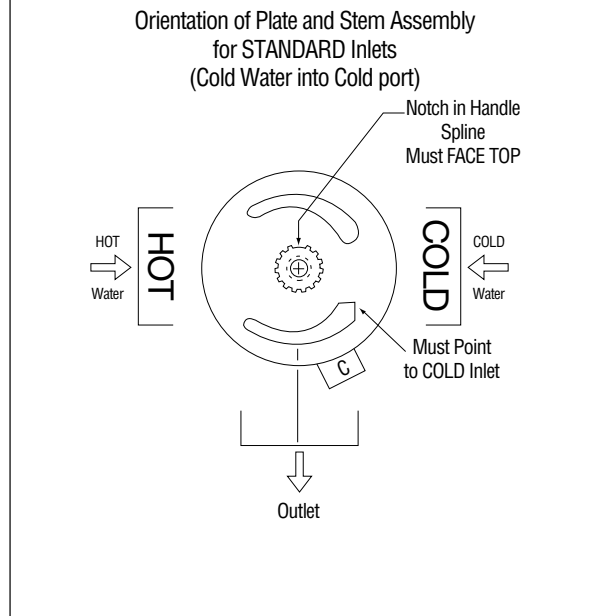
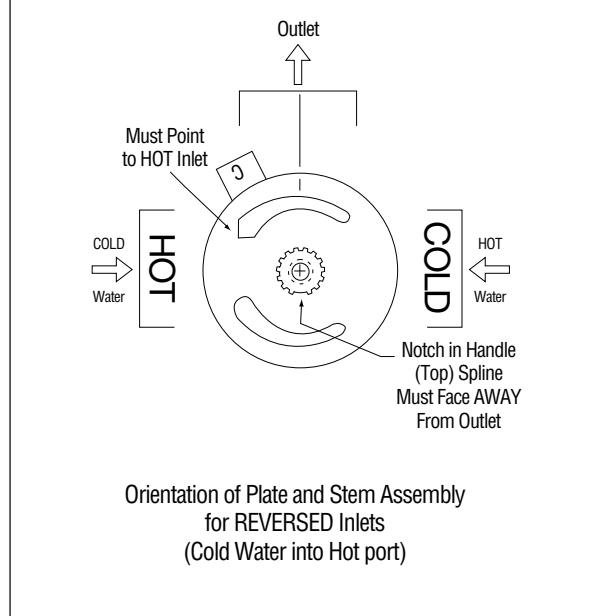
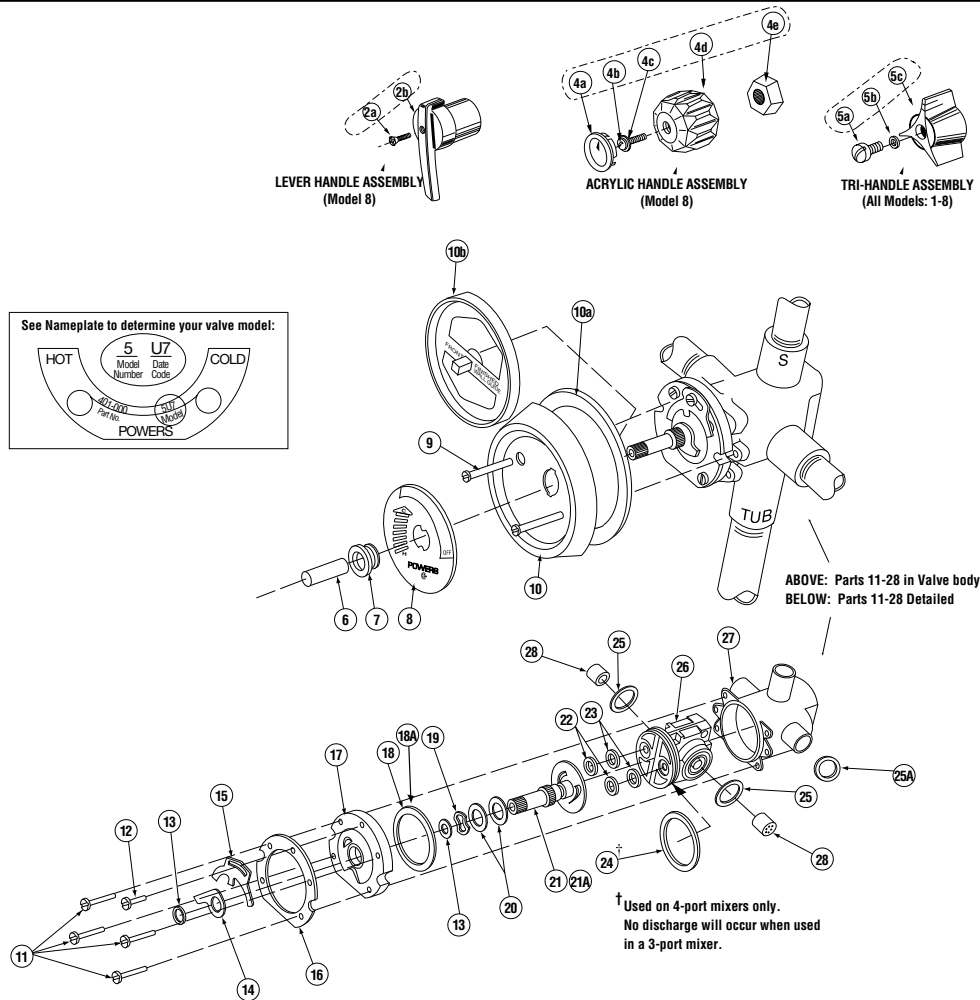

FIGURE 3 – REVERSED INLETS



PARTS



KIT	KIT NUMBER	KIT	KIT NUMBER
Lever Handle Assembly Kit (Model 8) Items 2a-2b (Qty: 1 each), 6	410-448	Balancing Cartridge Kit (4-port) Items 18, 22, 23, 24†, 25, 26	401-175
Acrylic Handle Assembly Kit (Model 8) Items 4a-4e (Qty: 1 each), 6	410-447	Flat Washers (bulk pack) Item 20 (Qty: 15)	410-368
Tri-Handle Assembly Kit Items 5a-5d (Qty: 1 each)	410-565	Wavy Washers (bulk pack) Item 19 (Qty: 10)	410-369
Dial Assembly Kit, Standard Items 7, 9, 10a, 10, 8	410-445	Gasket and Disk Replacement Kit Items 13, 18, 18a, 22, 23, 24†, 25	410-182
Dial Plates (bulk pack) Item 10 (Qty: 15)	410-413BP	O-Rings (bulk pack) Item 13 (Qty: 25)	410-366
Dial Plates (jumbo bulk pack) Item 10 (Qty: 25)	410-413JP	Oversize 410 Inlet Seal Kit 10a, 13, 22, 23, 24, 25, 25A	410-570
Retainers (bulk pack) Item 7 (Qty: 10)	410-367	Screws, for dial plate (bulk pack) Item 9 (Qty: 20)	420-216
Balancing Cartridge Kit (3-port) Items 18, 22, 23, 24†, 25, 26	410-183	Throttling Stem/Plate Replacement Kit Items 13, 18, 18a, 19, 20, 21, 22	410-378

† For use on 4-port mixers only. No discharge will occur when used in 3-port mixers.

* Sleeve (401-253) used on 419's only (not shown).

PARTS – SERIES 410 HYDROGUARD

Series 410 Hydroguard Pressure equalizing mixer. Poppet-type construction. Adjustable maximum temperature stop.

Item	Part Description	Part No.	Quantity	Material
2a-2b	Lever Handle Assembly (410 Model 8)	see kit #410-448		
2a	Lever Handle Screw (8-32 x 1-1/4")	*	1	C.P. Brass
2b	Lever Handle	*	1	C.P. Zinc
4a-4e	Acrylic Handle Assembly (410 Model 8)	see kit # 410-447		
4a	Plug Button and Insert	420-314	1	C.P. Brass
4b	Acrylic Handle Screw (8-32 x 3/4")	034-515K	1	C.P. Brass
4c	Washer	227-197	1	Neoprene
4d	Control Knob/Sleeve Assembly	420-310	1	Acrylic and Brass
4e	Acrylic Handle Insert	420-125	1	C.P. Zinc
5a-5d	Tri-Handle Assembly (All 410 Models: 1-8)	see kit # 410-565		
5a	Tri-Handle Screw	030-070	1	C.P. Zinc
5b	Washer	046-008K	1	C.R. Steel
5c	Tri-Handle	410-191	1	C.P. Brass
5d	Plug Button (not shown)	410-195	1	-
6	Sleeve	401-267	1	C.P. Copper
7	Retainer for Brass Stamped Standard Dial	see kit # 410-367		
7a	Retainer for Brass Stamped Deluxe Dial	410-417	1	Rubber
8	Dial Insert (Model 5) (not shown)	410-374	1	Aluminum
	Graphic Insert (not shown)	410-442	1	
9	Screws (2)	see kit # 420-216		
10	Dial Plate	see kit # 410-445		
10a	Gasket	see kit # 410-570		
10b	Rough-in Guide (All Models)	401-178	1	-
11	Bonnet Screws (10-32 x 1") (4)	030-885	4	Stainless Steel
12	Adjustment Stop Screw (10-32 x 5/16")	030-884	1	Stainless Steel
13	O-Rings (3/8" x 1/2" x 1/16") (2)	see kit # 410-182/410-570/410-378	1	
14	Maximum Temperature Stop	401-218	1	Brass
15	Adjustment Stop	401-278	1	Stainless Steel
16	Support Ring	410-377	1	Stainless Steel
17	Bonnet	401-162	1	Naryl
17a	Bonnet for 414 Valve (not shown)	410-393	1	Naryl
18	Bonnet Gasket (Rainbow Style)	see kit # 410-182/410-378		
18a	Bonnet O-Ring (Models 1-3 only) (not shown)	see kit # 410-182/410-378		
19	Wavy Washer	see kit # 410-378/410-369		
20	Flat Washers (4)	see kit # 410-368/410-378		
21	Throttling Stem	see kit #410-378		
21a	Throttling Stem for 419 Valve (not shown)	410-378A	1	Brass Stem Celcon Plate
22	Shut-off Discs (2)	see kit # 410-570/378, 182, 183, 401-175		
23	Quad Rings (2)	see kit # 410-570, 182, 183, 401-175		
24†	O-Ring (1-3/4" x 1-7/8" x 1/16")†	see kit # 410-570, 182, 183, 401-175		
25	O-Rings (1-3/4" x 1-3/16" x 3/32") (2)	see kit # 410-570, 182, 183, 401-175		
25A	O-Ring (oversized)	see kit # 410-570		
26	Balance Chamber (3-port valves)	see kit # 410-183		
	Balance Chamber (4-port valves)	see kit # 401-175		
27	Body, 4-Port	N/A		
	Body, 3-Port (not shown)	N/A		

† For use on 4-port mixers only. No discharge will occur when used in 3-port mixers.

SERVICING

1. Shut off upstream water supply.
2. Remove the dial assembly and handle. See page 3 for relationship of parts. Unscrew four cap screws and remove cap assembly by gently pulling on stem.
3. **TO REMOVE THE BALANCE CHAMBER**, using a balance chamber extraction tool (Part No. 401-202) is highly recommended. To use the extraction tool, follow instructions below:
 - a. Insert hooked ends of extraction tool into HOT and COLD outlet ports of the balance chamber (see Figure 4).
 - b. Insert screwdriver down through end of extraction tool.
 - c. Place a wood or plastic block (do *not* use metal) between screwdriver and valve body. Firmly ease screwdriver away and downward, using wood for added leverage as cartridge is gradually pulled out.
4. Replace necessary items and reassemble. A small amount of silicone gel on the cartridge, O-rings, and related surfaces will aid in the assembly.

CAUTION: Do not pinch cartridge O-rings during assembly.

5. Replace bonnet with new bonnet gasket. Proceed to step 6 to reset maximum temperature setting.

MAXIMUM TEMPERATURE SETTING

6. **MAXIMUM TEMPERATURE SETTING** (refer to Figure 5). This must be set on the job and following any maintenance or servicing to the valve. Mixer is factory set to pass full HOT water.
 - a. Loosen adjustment stop screw (do not remove). Gradually rotate stem counterclockwise to get desired maximum water temperature. (Maximum Temperature Stop will rotate along with the stem when the stem is rotated.)
 - b. Once stem has been rotated to desired temperature, slide adjustment stop clockwise until fin on adjustment stop touches the maximum temperature stop.
 - c. While holding adjustment stop in place, tighten adjustment stop screw.
 - d. Replace handle. Confirm maximum temperature has been set properly by operating the valve using the handle.

CAUTION: Adjustment stop must be present for proper operation.

FIGURE 4 – BALANCE CHAMBER REMOVAL

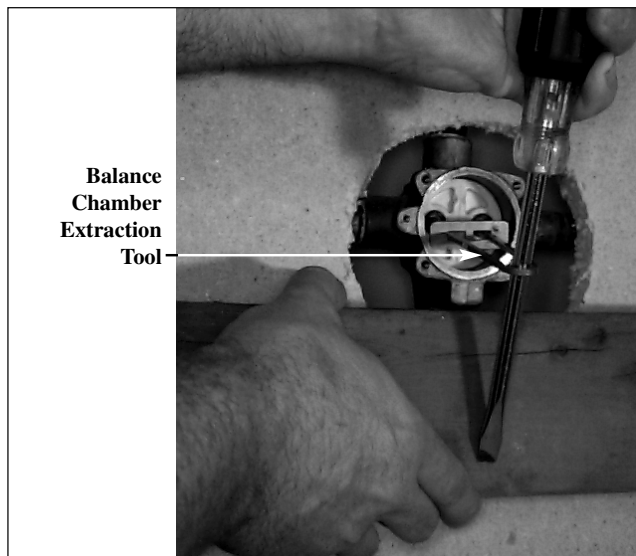
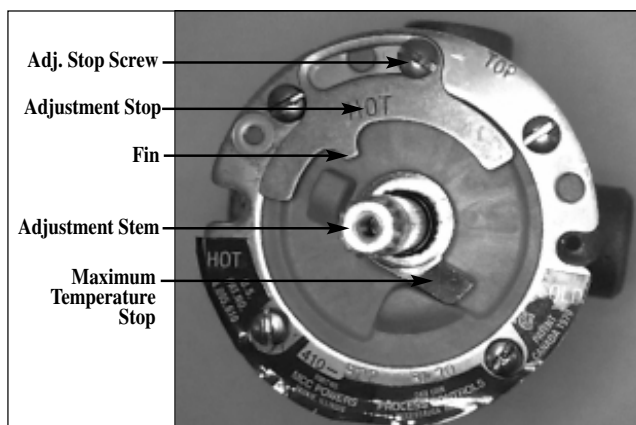

FIGURE 5 – MAXIMUM TEMPERATURE SETTING



TROUBLESHOOTING

Description	Recommended Repair Kit	Kit Number and Contents
1. Water leaks at stem and/or bonnet. 2. Flow of water continues after mixer is turned off.	Gasket and Disc Replacement	410-182 Items 13, 18, 18a 22, 23, 24,* 25 (includes bonnet O-ring for Models 1-3)
1. Variable or untempered discharge temperature.	Balance Chamber (3-port) †	410-183 Items 18, 22, 23, 24*, 25, 26, 28
	Balance Chamber (4-port) †	401-175 Items 18, 22, 23, 24*, 25, 26, 28
1. Flow continues after mixer is turned off. 2. Handle splines on stem damaged.	Throttling Stem and Plate Replacement	410-378 Items 13, 18, 18a 19, 20, 21, 22 (includes bonnet O-ring for Models 1-3)
1. Cartridge slips while seated in body. 2. Flow of water continues after mixer is turned off, and all other seals have been replaced.	Overize 410 Inlet Seal Kit**	410-570 Items 13, 22, 23, 24, 25, 25A (also includes overize O-ring for use with Models 1-8)**
1. To convert to Model 8 lever or acrylic handle.	Dial Assembly Kit Lever Handle Kit Acrylic Handle Kit	410-445 Items 7,9,10a, 10, 8 410-448 Items 2a-2b, 6 410-447 Items 4a-4e, 6

* **Use item 24 only in 4-port model.** No discharge will occur if item 24 is used in 3-port model.
 ** When using overize O-ring, discard ONE of the two regular sized O-rings normally used and use overize O-ring in its place.
 † 4-port valve models are: P416 and P417.
 3-port valve models are: P411, P412, P413, P414 and P419.

Notes:

1. Use silicone provided on all O-rings and related surfaces. Never use grease.
2. Some kits contain parts for all models; discard extra parts as appropriate.

ADA-COMPLIANT OPTIONS

When used together, Powers' lever handle and handshower meet ADA compliance standards. For complete ADA-required heights and other information on installing an ADA-compliant bathing system, refer to the ADAAG (Americans with Disabilities Act Accessibility Guidelines).

CALIFORNIA PROPOSITION 65 WARNING
WARNING: This product contains chemicals known to the State of California to cause cancer and birth defects or other reproductive harm. (Installer: California law requires that this warning be given to the consumer.)
 For more information: www.wattsind.com/prop65

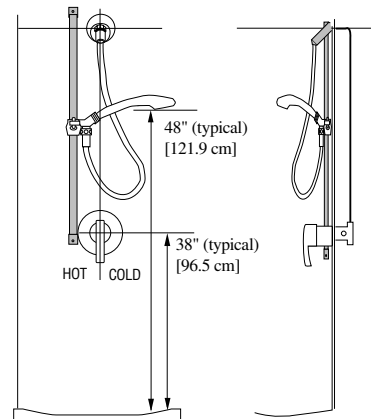

<p>POWERS A WATTS INDUSTRIES CO.</p>	<p>USA office: Phone: 800.669.5430 • Fax: 847.824.0627 www.powerscontrols.com Canadian office: Phone: 888.208.8927 • Fax: 888.882.1979 © 2003 Powers, a Watts Industries Co.</p>
---	---