



## Supply Fixture Series 430 Top Inlets/Top Outlet — Wall Mounted Cabinet

### Features ■

- Valve utilizes paraffin-based advanced thermal actuation technology to sense and adjust outlet temperature
- Dirt & lime resistant poppet and seat design
- Virtual shut-off if supply pressure fails
- Vandal-resistant locking mechanism to secure temperature setting
- Stainless steel or white painted cabinets
- Factory tested valve and piping
- Rotatable union triple-duty checkstops with filters, dial-thermometer, ball valve
- Rough bronze and chrome finishes



### Specifications ■

- Connections ..... See chart on the reverse
- Maximum Hot Water Supply Temperature..... 200° F (93° C)
- Minimum Hot Water Supply Temperature..... 15° F (8° C) above set point
- Minimum Flow\* ..... 0.5 gpm (1.9 lpm)
- Maximum Pressure Differential ..... 100 psid (689 kpa)
- Temperature Adjustment Range ..... 40-160° F (4-71° C)
- Listing/Compliance (Valve Only)..... ASSE 1017, CSA B125



Advanced Thermal Activation

\* Minimum flow when the valve is installed at or near hot water source w/re-circulated tempered water with a properly sized continuously operating re-circulating pump.

Flow Capacity When Tested To ASSE 1017 Standard									
Valve	CV 1 psi (7 kpa)	Min. Flowrate	Pressure Differential						
			5 psi (35 kpa)	10 psi (69 kpa)	15 psi (103 kpa)	20 psi (138 kpa)	30 psi (207 kpa)	45 psi (310 kpa)	60 psi (414 kpa)
431	3.73	4.0 gpm (15.0 lpm)	8.3 gpm (31.0 lpm)	11.8 gpm (45.0 lpm)	14.4 gpm (55.0 lpm)	16.7 gpm (63.0 lpm)	20.4 gpm (77.0 lpm)	25.0 gpm (95.0 lpm)	28.9 gpm (109.0 lpm)
432	6.71	7.0 gpm (26.0 lpm)	15.0 gpm (57.0 lpm)	21.2 gpm (80.0 lpm)	26.0 gpm (98.0 lpm)	30.0 gpm (114.0 lpm)	36.8 gpm (139.0 lpm)	45.0 gpm (170.0 lpm)	52.0 gpm (197.0 lpm)
433	11.93	10.0 gpm (38.0 lpm)	26.7 gpm (101.0 lpm)	37.7 gpm (143.0 lpm)	46.2 gpm (175.0 lpm)	53.4 gpm (202.0 lpm)	65.3 gpm (247.0 lpm)	80.0 gpm (303.0 lpm)	92.4 gpm (350.0 lpm)
434	18.63	15.0 gpm (57.0 lpm)	41.7 gpm (158.0 lpm)	58.9 gpm (223.0 lpm)	72.2 gpm (273.0 lpm)	83.3 gpm (315.0 lpm)	102.0 gpm (386.0 lpm)	125.0 gpm (473.0 lpm)	144.3 gpm (546.0 lpm)

## Dimensions ■

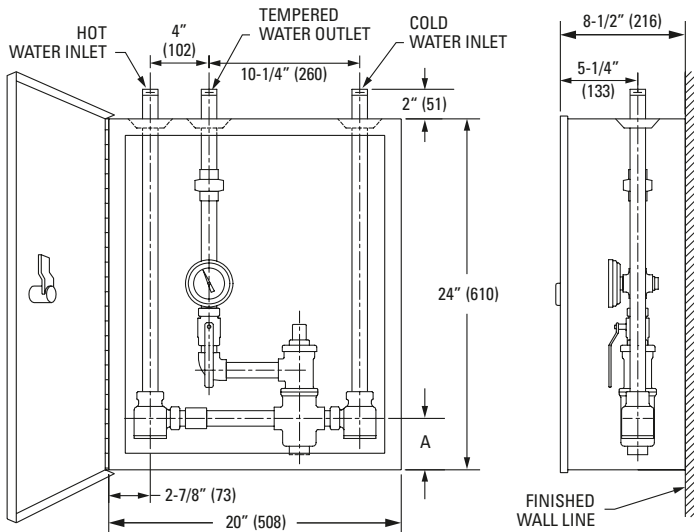

Dimension			
Valve	Inlets	Outlet	A
431	3/4" NPT	3/4" NPT	3-1/2" (89)
432	3/4" NPT	1" NPT	3-1/2" (89)
433	1-1/4" NPT	1-1/4" NPT	5" (127)
434	1-1/4" NPT	1-1/2" NPT	5" (127)

Note:  
 1) Dimensions in brackets are in mm.  
 2) Dimensions are shown  $\pm 1/4"$

## Ordering Information ■

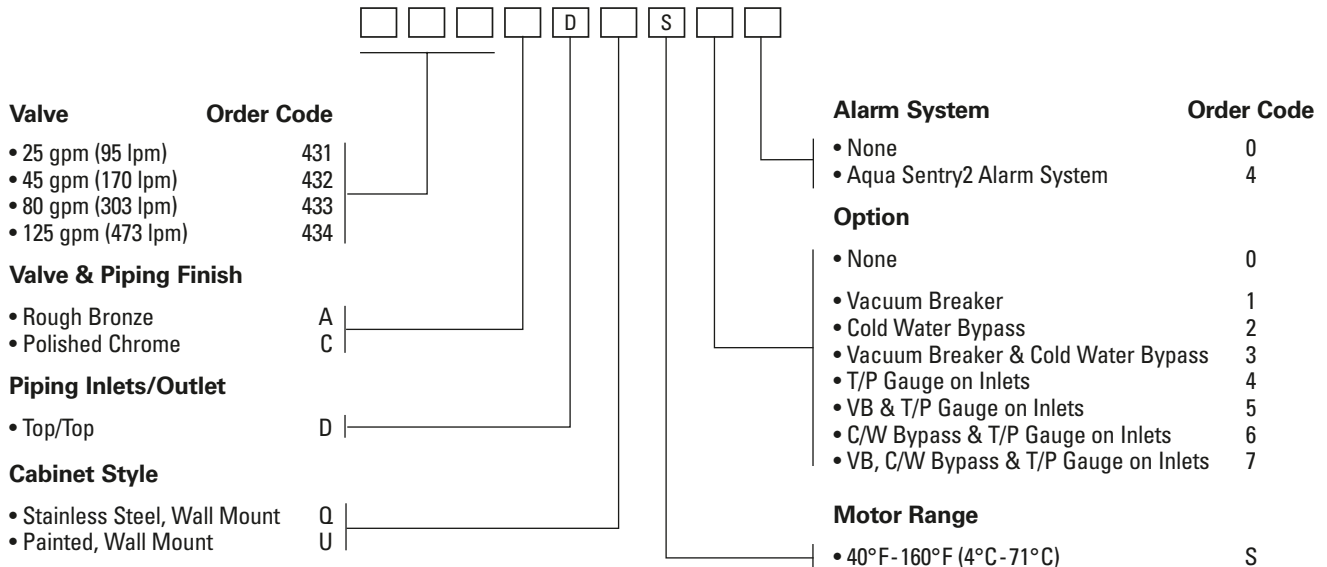

## Recirculation Piping Diagram ■

Please see Piping Diagram Section of this catalog.

## Typical Specification ■

Supply fixture shall feature top inlets/top outlet configuration with wall mount stainless steel or painted steel construction cabinet. Valves shall be HydroGuard® 430 master tempering series valve and feature paraffin-based, advanced thermal actuation technology for near instantaneous response and possess approach temperature of 15°F/8°C. Minimum flows shall be 4.0 gpm/15 lpm (431), 7.0 gpm/26 lpm (432), 10 gpm/38 lpm (433) and 15.0 gpm/57 lpm (434) when tested to ASSE 1017. Piping and valve shall be factory tested, and include ball valve and thermometer. Supply fixture shall be a Powers' 43\_\_D\_S\_\_\_. All alternatives must have a written approval prior to bidding.

### ENGINEERING APPROVAL

Project: \_\_\_\_\_  
 Contractor: \_\_\_\_\_  
 Architect/Engineer: \_\_\_\_\_

**POWERS™**

© 2005 POWERS, a division of Watts Water Technologies, Inc.  
 USA Office: Phone: 800.669.5430 Fax: 847.229.0526  
 Canadian Office: Phone: 888.208.8927 Fax: 888.882.1979

www.powerscontrols.com