

SPECIFICATION

DescriptionRemodeling Plate for e420 Valve
MaterialStainless Steel
FinishPolished
Shipping Weight 1.0 lb. (0.5 kg.)

DIMENSION

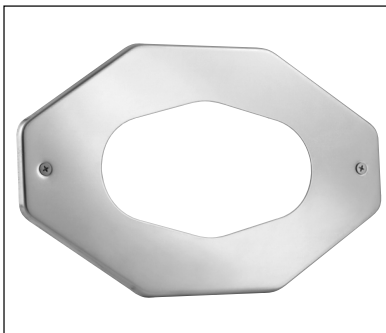
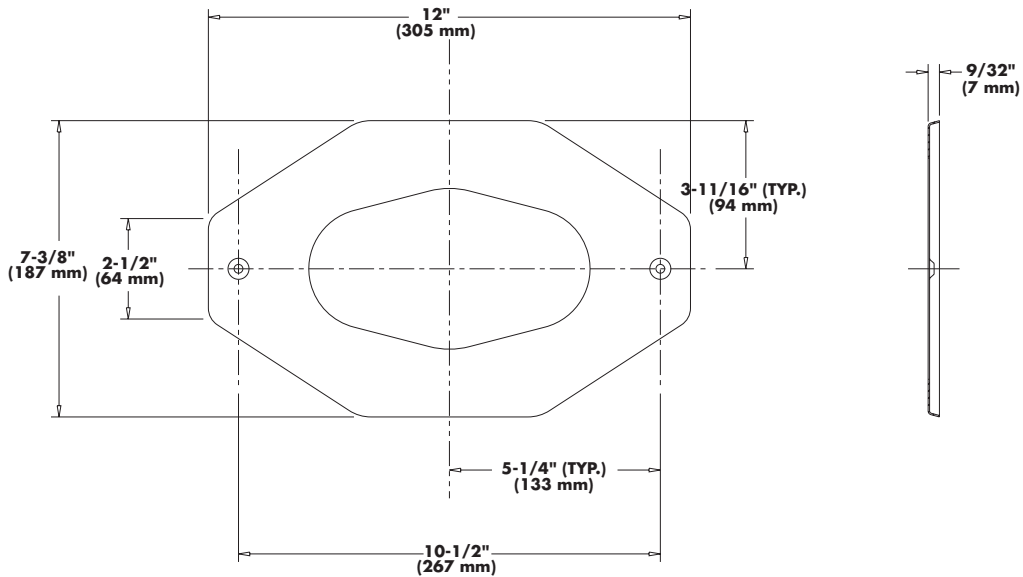

ENGINEERING APPROVAL

Project: _____

Contractor: _____

Architect/Engineer: _____