

POWERS

A WATTS INDUSTRIES CO.

HydroGuard® T/P
Series e700

INSTALLATION INSTRUCTIONS Cartridge Replacement

e700 CARTRIDGE REPLACEMENT INSTRUCTIONS

The following instructions explain how to replace the cartridge to your Series e700 valves:

Figure 1

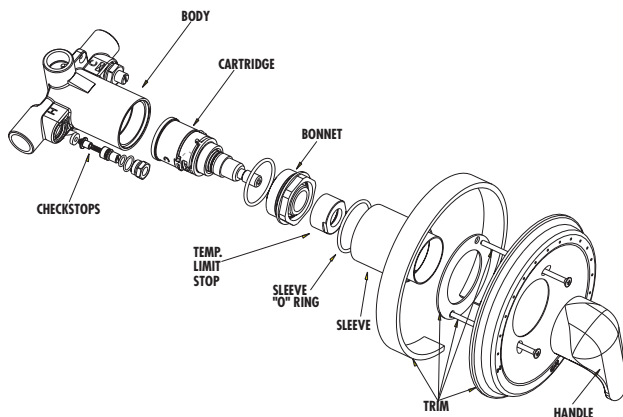

Disassembly:

1. Remove the handle and trim plate.
2. Turn off hot & cold water supply-stops.
3. Remove bonnet.
4. Remove all internal components from the valve body.
5. At this point you should have an empty valve body.

You are now ready to put the new cartridge into your existing valve.

Reassembly:

1. Ensure the inside of the valve body is free of deposits and debris. Clean as necessary.
2. Place the cartridge into the body ensuring following:
 - a) "C" on the cartridge should be on the cold inlet side.
 - b) Align tab on the back of the cartridge to the groove in the body.
3. While holding cartridge firmly, screw bonnet into body; tighten to 100 + 20/-0 in-lbs.
4. Turn the hot and cold water supplies back on and verify there is no leakage.

Maximum Temperature Setting/Handle Rotation Stop

The handle rotation setting must be adjusted to limit the distance the user can rotate the handle towards the full hot water position.

CAUTION: Any repair or modification of the valve may affect the high temperature setting. The maximum temperature setting must be checked by the installer before use.

5. Adjust the valve to the desired maximum outlet temperature [110°F (43°C) max]. Screw on the high temp. limit stop until it touches the stem shoulder.
6. Turn the stem clockwise until the water stops. Open valve to full hot position and verify max outlet temperature setting.
7. Place sleeve "O" Ring on the bonnet shoulder. Slide sleeve over the "O" Ring until it stops.
8. Replace trim plate and handle.

If you have any problems, comments, or suggestions, please contact your Powers representative. We are interested in feedback from the field.

CALIFORNIA PROPOSITION 65 WARNING

WARNING: This product contains chemicals known to the State of California to cause cancer and birth defects or other reproductive harm. (Installer: California law requires that this warning be given to the consumer.)

For more information: www.wattsind.com/prop65

POWERS
A WATTS INDUSTRIES CO.

© June 2003 Powers, a Watts Industries Co.
USA Phone: 800.669.5430 • www.powerscontrols.com
Canadian office: Phone: 888.208.8927