

POWERS

A WATTS INDUSTRIES CO.

HydroGuard® T/P
Series e700

INSTALLATION INSTRUCTIONS

Note: Installation should be in accordance with accepted plumbing practices. Flush all piping thoroughly before installation.

TO INSTALL

- Position mixer $1-15/16" \pm 1/2"$ [49mm \pm 13mm] from inlet center to finished wall surface. The tub outlet port is marked "TUB" and should face down. Facing front of mixer, connect hot water to left side and connect cold water to right side. The valve has "C" and "H" cast into the body near the appropriate inlet ports.
- Valve is factory-set for standard inlets. If **reversed inlets** are required due to back-to-back installation (Cold water supply on the left and Hot water supply on the right), follow instructions a–d below:
 - Connect **cold inlet to hot port ("H")** and **hot inlet to cold port ("C")**. **Note:** Do not turn valve upside down. If valve is upside down, water will not flow properly through tub spout or showerhead.
 - Turn water off with checkstops, remove bonnet and cartridge.
 - Reinstall cartridge. "H" on the cold side of the valve body and "C" should be on the hot side of the valve body.
 - Reinstall bonnet with high temperature limit stop on it.

Note: Be certain that valve opens in full cold!

 - Hot and Cold inlets should be re-identified for reversed inlets to avoid confusion during future maintenance.
- For **tub and shower installations**, see Figure 1. Pipe bottom outlet port "TUB" directly to the diverter tub spout. The mixer body is designed to operate without the use of a twin ell. Pipe top outlet port "S" to the showerhead.

- For **shower only installation**, see Figure 2. Pipe top outlet port "S" directly to the showerhead and plug bottom port.
- Rough-in guide installation...
 - When piping installation is completed and before doing the finished wall, slide rough-in guide onto the mixer stem and press fit into place. (See Figure 4.)
 - The rough-in guide will insure the proper size opening for mixer and checkstop shut-off and repair accessibility, as well as protect the chrome-plated sleeve from damage during drywall and tile installation.
- To install dial gaskets, peel backing off gaskets and attach gaskets to inside of dial plate.
- After wall is completed, remove rough-in guide and attach dial assembly and handle to mixer body with the screws furnished. See Figure 3.

CAUTION: When soldering during installation process, do not heat the valve any higher than the temperature required to flow solder. Excessive overheating of the valve may cause damage to the cartridge mechanism. **By following this recommendation, you will be able to solder the valve without removing either the cartridge or the checkstop internals.** If either brazing or resistance (electric) solder is to be used, all valve internals must be removed.

- Maximum temperature setting adjustment (see Figure 5) must be set on the job to in no case greater than 110°F [43°C]. The high temperature limit stop is located on the bonnet. Rotate handle to the maximum desired outlet temperature. With an open-end wrench, screw high temperature limit stop into bonnet until it touches stem's shoulder. Close valve and open it to full hot to verify settings.

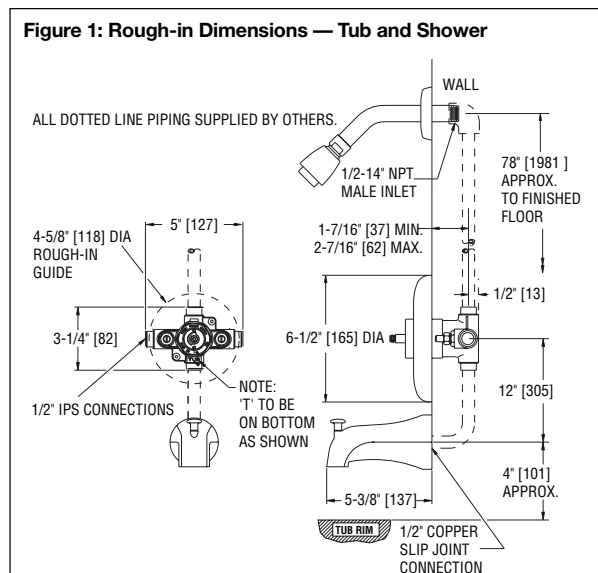

Dimensions in inches [millimeters]

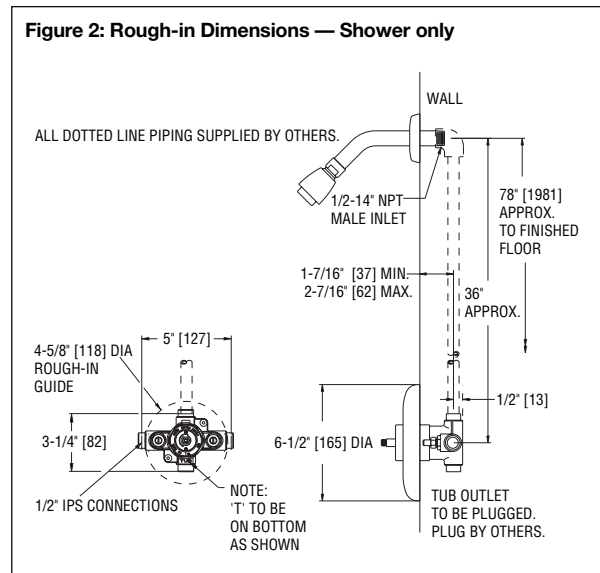

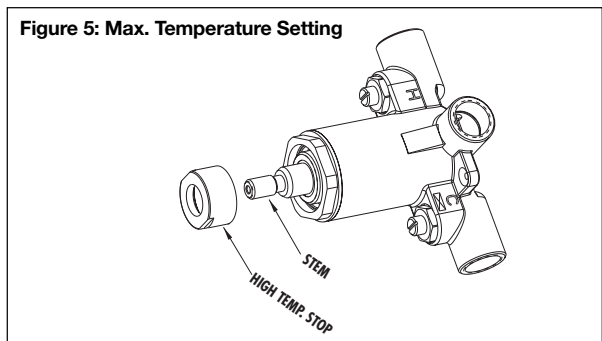
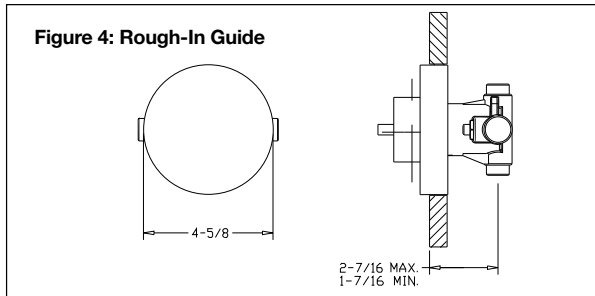
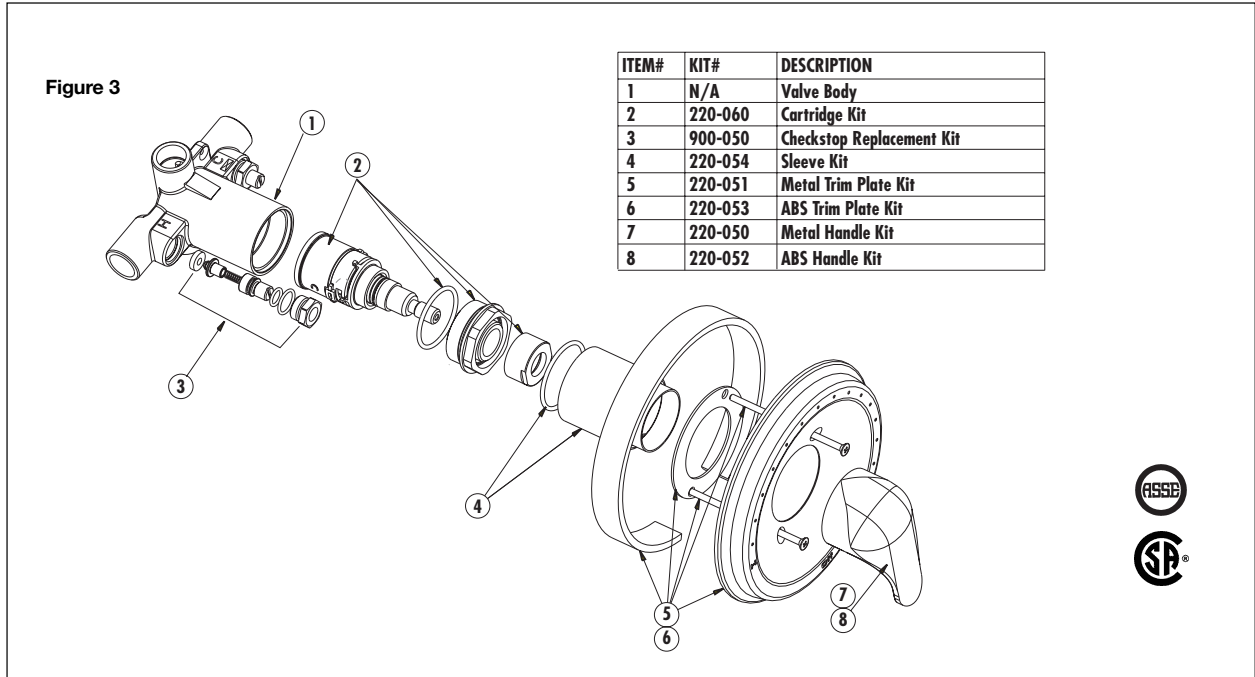

TROUBLESHOOTING

Description	Troubleshooting	Repair Kit No.
Cartridge Kit	<ul style="list-style-type: none"> Water leaks at valve stem and/or bonnet. Water leaks at valve shut-off. Water temperature changes during shower. 	220-060
Checkstop Replacement Kit	<ul style="list-style-type: none"> Checkstop leaks or will not shut-off completely. 	900-050

CALIFORNIA PROPOSITION 65 WARNING
WARNING: This product contains chemicals known to the State of California to cause cancer and birth defects or other reproductive harm. (Installer: California law requires that this warning be given to the consumer.)
 For more information: www.wattsind.com/prop65

POWERS
 A WATTS INDUSTRIES CO.

© June 2003 Powers, a Watts Industries Co.
 USA Phone: 800.669.5430 • www.powerscontrols.com
 Canadian office: Phone: 888.208.8927