

# POWERS

A WATTS INDUSTRIES CO.

## INSTALLATION INSTRUCTIONS

### ESP™ PIEZO PUSH BUTTON CONCEALED SHOWERS

#### NEW INSTALLATION

**Note:** Requires 1 3/8" diameter opening

1. Assemble push button components as shown in figure 1. During assembly, make sure electrical switch "B" sits squarely in housing "A." Take care not to pinch electrical wires while assembling. Lock electrical switch securely into place with threaded pipe "C."

Figure 1

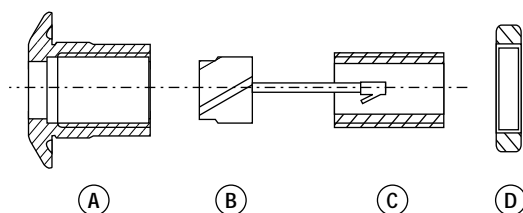

All pieces must be adequately tightened to prevent vandalism and tampering. Finished assembly should resemble figure 2.

Figure 2

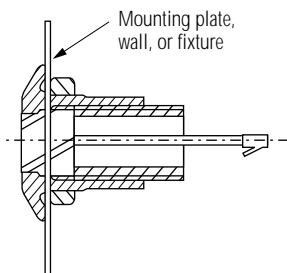

2. Place finished assembly through 1 3/8" diameter opening and secure firmly with brass locknut "D" against backside of wall or fixture.
3. Connect wiring (from push button to control box) using modular telephone connector. Powers' new push button switch assembly is completely compatible with all current ESP electronic components, including both the group and individual control centers.

#### CALIFORNIA PROPOSITION 65 WARNING

**WARNING:** This product contains chemicals known to the State of California to cause cancer and birth defects or other reproductive harm. (Installer: California law requires that this warning be given to the consumer.)

For more information: [www.wattsind.com/prop65](http://www.wattsind.com/prop65)

#### RETROFIT FOR EXISTING INSTALLATION

**Note:** Used when hole through wall is greater than 2"

1. Assemble push button as detailed under New Installation instructions.
2. Two additional mounting plates are required as shown in figure 3. See table 3.1 for proper sizing and kit numbers. Place stainless (round) mounting plate "A" over push button assembly. Place assembly with mounting plate through wall. Secure assembly by placing brass (rectangular) mounting plate "B" on back side of wall (covering opening) and tighten down with brass lock nut.

Figure 3

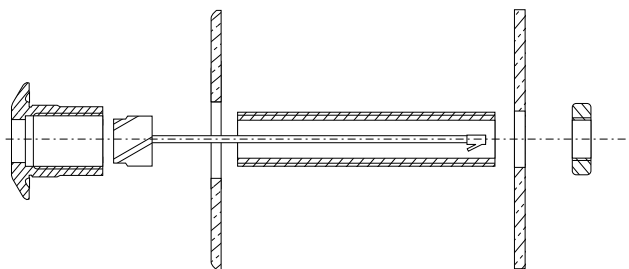
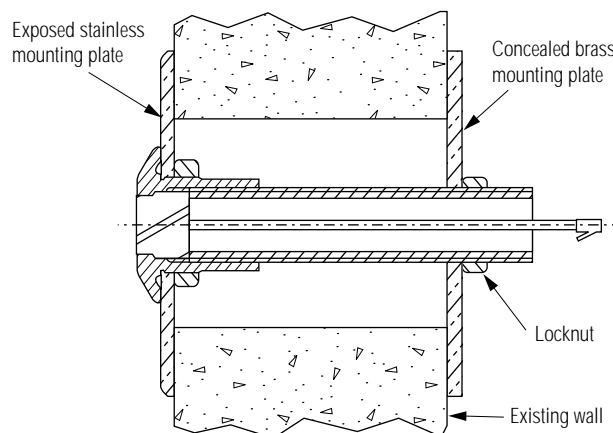

Table 3.1

Thru Hole Diameter	Exposed Stainless Mounting Plate	Concealed Brass Mounting Plate
> 2" ≤ 3"	444-304A	444-285A
> 3" ≤ 4"	444-304B	444-285B
> 4" ≤ 5"	444-304C	444-285C
> 5" ≤ 6"	444-304D	444-285D

Final installation will resemble Figure 4.

Figure 4



(Continued on reverse)

Table 3.2: ESP™ Push Button Assemblies for Various Wall Thicknesses

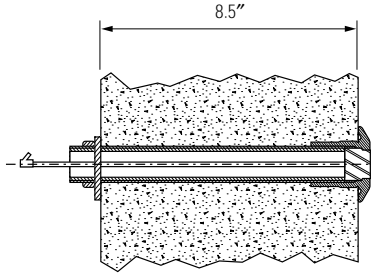
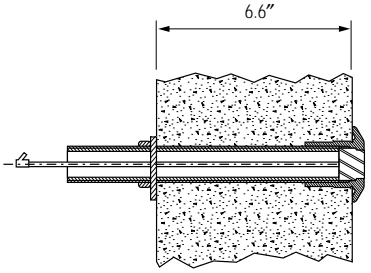
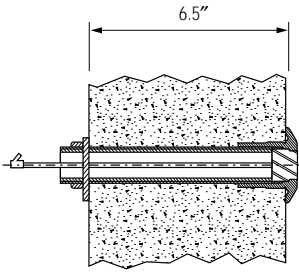
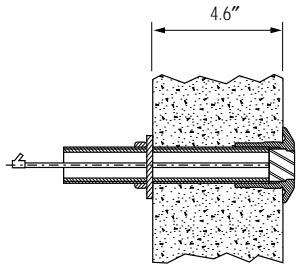
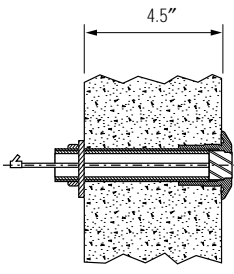
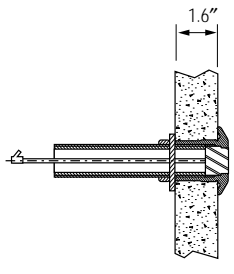
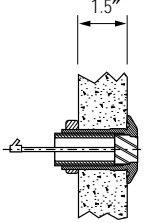
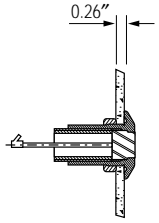
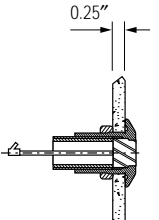
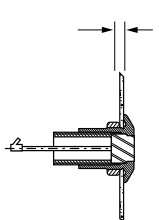
Wall Thickness	Order Code*	Maximum Wall Thickness	Minimum Wall Thickness
6.6" ≤ 8.5"	447-7		
4.6" ≤ 6.5"	447-6		
1.6" ≤ 4.5"	447-5		
0.26" ≤ 1.5"	447-4		
0" ≤ 0.25"	447-3		

★ See price list addendum EPL-PL

**POWERS**  
A WATTS INDUSTRIES CO.

USA office: Phone: 800.669.5430 • Fax: 847.824.0627  
www.powerscontrols.com  
Canadian office: Phone: 888.208.8927 • Fax: 888.882.1979  
© 2002 Powers, a Watts Industries Co.